

Chroma-Q®

2inspire™

100 / 200 / 300

USER MANUAL



Chroma-Q®
BRILLIANT SOLUTIONS

Part Numbers: CQ1501-1000, CQ1501-1005, CQ1501-1010, CQ1501-1015,
CQ1502-1000, CQ1502-1005, CQ1502-1010, CQ1502-1015,
CQ1503-1000, CQ1503-1005, CQ1503-1010, CQ1503-1015

(Model: 1501-1000, 1501-1005, 1501-1010, 1501-1015
1502-1000, 1502-1005, 1502-1010, 1502-1015
1503-1000, 1503-1005, 1503-1010, 1503-1015)



Warranty Statement

Chroma-Q® warrants to the original purchaser, with proof of purchase, that its delivered products shall be free from defects in material and workmanship under normal use for a period of 24 months from date of shipment.

Chroma-Q® will repair, or at its option, provide an equivalent item or replace, the defective product during the stated warranty period. This warranty applies only to the repair or replacement of the product and only when the product is properly handled, installed and maintained according to Chroma-Q® instructions. This warranty excludes defects resulting from improper handling, storage, installation, acts of god, fire, vandalism or civil disturbances. Purchaser must notify Chroma-Q® in writing within 14 days of noticing the defect. This warranty excludes field labor or service charges related to the repair or replacement of the product.

The warranty contained herein shall not extend to any finished goods or spare parts from which any serial number has been removed or which have been damaged or rendered defective (a) as a result of normal wear and tear, willful or accidental damage, negligence, misuse or abuse; (b) due to water or moisture, lightning, windstorm, abnormal voltage, harmonic distortion, dust, dirt, corrosion or other external causes; (c) by operation outside the specifications contained in the user documentation; (d) by the use of spare parts not manufactured or sold by Chroma-Q® or by the connection or integration of other equipment or software not approved by Chroma-Q® unless the customer provides acceptable proof to Chroma-Q® that the defect or damage was not caused by the above; (e) by modification, repair or service by anyone other than Chroma-Q®, who has not applied for and been approved by Chroma-Q® to do such modification, repair or service unless the customer provides acceptable proof to Chroma-Q® that the defect or damage was not caused by the above; (f) due to procedures, deviating from procedures specified by Chroma-Q® or (g) due to failure to store, install, test, commission, maintain, operate or use finished goods and spare parts in a safe and reasonable manner and in accordance with Chroma-Q's instructions (h) by repair or replacement of engines without factory training.

The warranty contained herein shall not apply to finished goods or spare parts which are sold "as is", as "second-hand", as used", as "demo" or under similar qualifications or to consumables ("consumables" is defined as any part(s) of goods or part(s) for use with goods, which part(s) of goods or part(s) for use with goods are consumed during the operation of the goods and which part(s) of goods or part(s) for use with goods require replacement from time to time by a user such as, but not limited to, light bulbs).

The warranty contained herein shall not apply, unless the total purchase price for the defective finished goods or spare parts has been paid by the due date for payment.

The warranty contained herein applies only to the original purchaser and are not assignable or transferable to any subsequent purchaser or end-user.

This warranty is subject to the shipment of the goods, within the warranty period, to the Chroma-Q® warranty returns department, by the purchaser, at the purchaser's expense. If no fault is found, Chroma-Q® will charge the purchaser for the subsequent return of the goods.

Chroma-Q® reserves the right to change the warranty period without prior notice and without incurring obligation and expressly disclaims all warranties not stated in this limited warranty.



Disclaimer

The information contained herein is offered in good faith and is believed to be accurate. However, because conditions and methods of use of our products are beyond our control, this information should not be used in substitution for customer's tests to ensure that Chroma-Q® products are safe, effective, and fully satisfactory for the intended end use. Suggestions of use shall not be taken as inducements to infringe any patent. Chroma-Q® sole warranty is that the product will meet the sales specifications in effect at the time of shipment. Your exclusive remedy for breach of such warranty is limited to refund of purchase price or replacement of any product shown to be other than as warranted.

Chroma-Q® reserves the right to change or make alteration to devices and their functionality without notice due to our ongoing research and development.

The Chroma-Q® 2inspire™ 100 / 200 / 300 range has been designed specifically for the lighting industry. Regular maintenance should be performed to ensure that the products perform well in the entertainment environment.

If you experience any difficulties with any Chroma-Q® products please contact your selling dealer. If your selling dealer is unable to help please contact support@Chroma-Q.com. If the selling dealer is unable to satisfy your servicing needs, please contact the following, for full factory service:

Outside North America

Tel: +44 (0)1494 446000

Fax: +44 (0)1494 461024

Support@Chroma-Q.com

North America

Tel: 416-255-9494

Fax: 416-255-3514

support@Chroma-Q.com

For further information please visit the Chroma-Q® website at www.Chroma-Q.com.

Chroma-Q® and inspire are trademarks, for more information on this visit

www.Chroma-Q.com/trademarks.

The rights and ownership of all trademarks are recognized. "Art-Net™ designed by and copyright artistic licence"

Important notice:

As per the requirements in the occupational safety and health administration standards for product approval, please refer to the OSHA web pages <http://www.osha.gov/dts/otpca/nrtl/> for information on the list of nationally recognized testing laboratories (NRTL) and the scope of recognition.

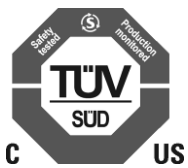

Safety information



WARNING!

Read the safety precautions in this section before installing, powering, operating or servicing this product.



Warning!
Safety Hazard.
Risk of severe injury or death.



Warning!
Fire Hazard.



Warning!
Hazardous Voltage.
Risk of severe lethal electric shock.



Warning!
Refer to User manual.

Warning!

Read the user manual before installing and operating the Chroma-Q® 2inspire™ 100 / 200 / 300. For future reference, keep and use the manual.

Safety precautions given in user manual must be followed at all times and the manuals of all the devices you connect it to. Observe all the warnings printed on devices and in manuals. Make sure whoever is involved in working on or using the 2inspire™ 100 / 200 / 300 has carefully read and understood all the safety precautions and lasted warnings.

Install, connect, operate and service devices only as described in this manual and in connected devices' manuals and only in accordance with local laws and regulations.

All Chroma-Q® manuals are supplied with devices and are also available for download from www.Chroma-Q.com.

2inspire™ 100 / 200 / 300 does not have user-serviceable parts. Refer any operation not described in this manual to support@Chroma-Q.com.

If you experience difficulties with any Chroma-Q products please contact your local dealer. If your local dealer is unable to help then please contact support@Chroma-Q.com.

If you are having trouble finding what you are looking for on our website, then contact our Chroma-Q marketing department by sending an email to marketing@Chroma-Q.com.

PROTECTION FROM ELECTRIC SHOCK

Use only the cables specified in this manual and on the Chroma-Q® website at www.Chroma-Q.com to interconnect devices in the installation. If the specified cables are not long enough for an intended cable run, consult Chroma-Q® for assistance in finding or creating a safe alternative solution.

Provide a means of locking out ac mains power that allows power to the installation to be shut down and made impossible to reapply, even accidentally, during work on the installation.

Shut down power to the installation during service and when it is not in use.

Before applying power to the installation, check that all power distribution equipment and cables are in perfect condition and rated for the current requirements of all connected devices.

Isolate the installation from power immediately if any product, power cable or power plug is in any way damaged, defective or wet, or if it shows signs of overheating.

Do not immerse a 2inspire™ 100 / 200 / 300 fixture in water or expose it to high-pressure water jets.

PROTECTION FROM BURNS AND FIRE

The 2inspire™ 100 / 200 / 300 is cooled passively by natural air convection. Provide adequate clearance for airflow around the fixtures.

Do not operate the 2inspire™ 100 / 200 / 300, if the ambient temperature (t_a) exceeds 40° C (104° F).

Do not modify the 2inspire™ 100 / 200 / 300, in any way not described in this manual or install other than genuine Chroma-Q® parts.

Use only accessories approved by Chroma-Q®.

PROTECTION FROM INJURY

Ensure that the installation hardware and supporting surface or structure can hold at least 10 times the weight of all the devices they support.

Block access below the work area and work from a stable platform whenever installing, servicing or moving the 2inspire™ 100 / 200 / 300.

As soon as work is completed, check that all hardware and components are securely fastened to supporting structures.

Make sure there are no flammable materials close to the product during operation.

Avoid direct eye exposure to the light source while the product is on.

Never try to repair the product. Repairs carried out by unskilled people can lead to damage or malfunction.

Please contact the nearest authorized dealer or contact support@Chroma-Q.com.

KEEP THIS USER MANUAL FOR FUTURE CONSULTATION. IF THIS PRODUCT IS USED BY ANOTHER USER, BE SURE THAT THEY ALSO RECEIVE THIS DOCUMENT.



Table of Contents

Contents

Table of Contents	1
Product Overview.....	3
Energy-Efficient.....	3
Convection Cooled	3
Long Life.....	3
Operation.....	4
Unpacking the Units	4
Cabling.....	5
Power (PoE)	6
Mounting.....	7
Optional Mounting Kits or accessories for 2inspire™ 100	8
Optional Mounting Kits or accessories for 2inspire™ 200	9
Optional Mounting Kits or accessories for 2inspire™ 300.....	10
2inspire™ Pendant Mount Kit choices.....	11
Beam control, Diffusion.....	12
Photometric and IES Data.....	12
Installing the diffusion filter.	13
Controlling the 2inspire™.....	15
Art-Net™ or sACN?.....	15
Using DMX-Workshop with 2inspire™.....	15
Start DMX-Workshop™.....	16
Setting the Protocol Art-Net™ or sACN.....	18
Setting the DMX address,.....	19
Setting the Universe and device name.....	19
Identifying fixture remotely.....	20
Changing IP Address and Subnet Mask.....	20
Setting the IP address,.....	21
Right-click on the fixture, click on Advanced and then Configure IP Address	21
Additional RDM Commands.....	21
Understanding the new Chroma-Q Gen3 color engine control.....	22
Control Personalities	23
I - Single channel Intensity:	23
IK - Intensity and CCT:.....	23
IKT - Intensity, CCT, Tint:.....	23

RGB – RGB	23
IRGB – Intensity, RGB	23
IHS – Intensity, Hue(color) and Saturation	23
IKTHS – Intensity, CCT, Tint, Hue, Saturation	24
16 bit control:	24
Channel layout	24
Chroma-Q® 2inspire™ 100/200/300 (I) Intensity Personality	25
Chroma-Q® 2inspire™ 100/200/300 (IK) Intensity and CCT Personality	26
Chroma-Q® 2inspire™ 100/200/300 (IKT) Intensity, CCT and Tint Personality	27
Chroma-Q® 2inspire™ 100/200/300 (RGB) RGB+magic white Personality	29
Chroma-Q® 2inspire™ 100/200/300 (IRGB) Intensity,RGB+magic white Personality	30
Chroma-Q® 2inspire™ 100/200/300 (IHS) – Intensity, Hue, Saturation Personality	31
Chroma-Q® 2inspire™ 100/200/300 (IKTRGB) Intensity, CCT, Tint, RGB Personality	32
Chroma-Q® 2inspire™ 100/200/300 (IKTRGB) Intensity, CCT, Tint, RGB Personality	33
Chroma-Q® 2inspire™ 100/200/300 (IKTHS) Intensity, CCT, Saturation, Hue Personality	34
Chroma-Q® 2inspire™ 100/200/300 (IKTHS) Intensity, CCT, Saturation, Hue Personality	35
Chroma-Q® 2inspire™ 100/200/300 **(CTRL) Control channel	36
Chroma-Q® 2inspire™ 100/200/300 CCT control	38
RDM Commands	39
RDM Standard commands	39
RDM Custom commands	40
Dimmer curves	41
Hue and Saturation control	41
Thermal Performance	42
Troubleshooting	42
Reset / Test Switch	43
Updating the fixture firmware	43
Maintenance	44
Tips and tricks	44
Specifications	45
Drawings – Measurements in Metric and Imperial	46
2inspire™ 100 line drawing	46
2inspire™ 200 line drawing	47
2inspire™ 300 line drawing	48
Accessories	49
Common to all three models	49
2inspire 100 Accessories	49
2inspire 200 Accessories	50
2inspire 300 Accessories	50

Product Overview

The Chroma-Q® 2inspire™ 100 / 200 / 300 are compact yet powerful lighting tools that serve multiple purposes and are designed to complement the highly acclaimed inspire™ series fixtures. They incorporate cutting-edge technologies from the popular Chroma-Q® Inspire™ range. With a ~22-degree beam angle and an elegant housing suitable for venues with low ceilings, these fixtures offer versatility. They can be controlled using LAN through industry-revolutionizing POE control. The 2inspire™ delivers an impressive range of mixed colors and "true" whites without any visible color separation shadows. Furthermore, the 2inspire™ range offers a wide selection of whites, soft pastels, and bold saturates, all available from a single fixture. Additionally, the energy-efficient LED design of the 2inspire™ results in reduced maintenance and operating costs.

Energy-Efficient

The Chroma-Q® 2inspire™ 100 / 200 / 300 consumes significantly less power compared to traditional fixtures, without compromising on performance. In addition to the reduced power consumption, these fixtures also generate less heat, resulting in a cooler environment and lower air conditioning expenses.

Convection Cooled

The 2inspire™ 100 / 200 / 300 incorporates the same reliable convection cooling technology found in other Chroma-Q® LED fixtures. This technology eliminates the need for noisy cooling fans, ensuring completely silent operation.

Long Life

The Chroma-Q® 2inspire™ 100 / 200 / 300 relies on LED technology, which guarantees consistent and long-lasting performance. As a result, there is no need for expensive regular maintenance typically required by conventional fixtures.



Note: HANDHELD COLOR METERS

Most handheld colour meters provide a limited measuring range for led fixtures, which often results in inconsistent and unreliable data.

All photometric values listed in this document are based on testing and measurements conducted by certified independent laboratories with reference to the IES standards.

Operation

Unpacking the Units

The package includes a 2inspire™ 100 / 200 / 300 fixture and a Quick Start Guide. We recommend that you keep the original packaging in case the item needs to be returned.

Included with the fixture is a safety bracket and a Gel holder C ring for IP20 models and only the safety bracket for IP65 models. The purpose of Gel holder C ring is explained in detail in section 3.1 of this manual.

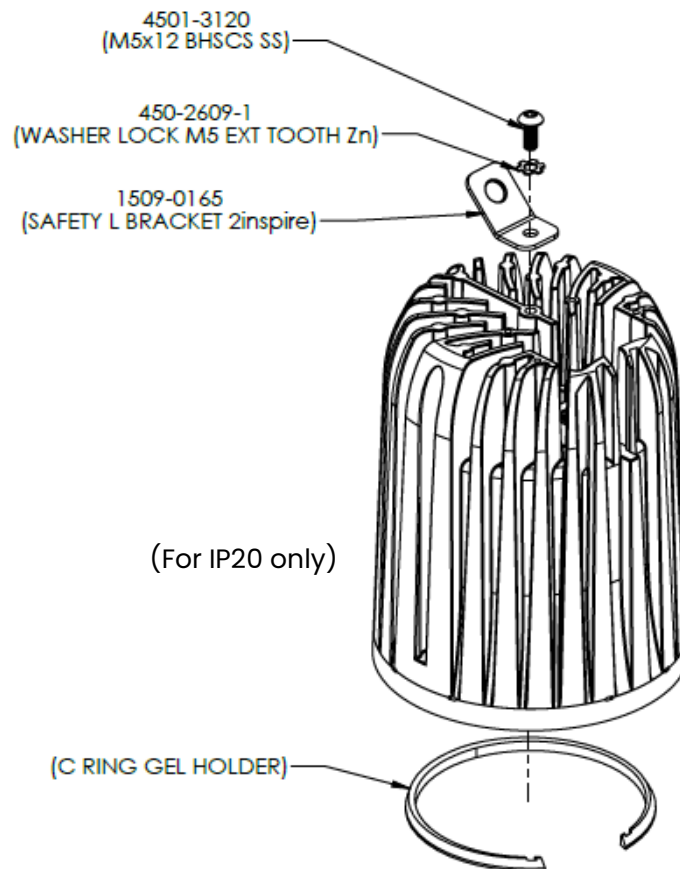

Cabling

The 2inspire™ 100, 200 and 300 make use of the IEEE 802.3 PoE standard for power and data transport. Power over Ethernet (PoE) is a technology that simultaneously carries electric power and data on Ethernet cables. It has several advantages:

Shielded cables are not needed nor recommended, when using shielded cables, **do not connect the shield to ground** on the fixture side to avoid any possible ground loop.

Simplified Network Cabling: PoE simplifies the cabling requirements for network devices, providing both electric power and data needs to lighting devices, such as 2inspire PoE fixtures.

Reduced Installation Costs: With a single cable delivering both power and data simultaneously, PoE installation costs are less than the cost of traditional wiring.

Safety: Power from a single source (one Cat5e or Cat6e Ethernet cable) rather than multiple adapters and sockets makes installation straightforward with fewer steps and potential hazards.

Flexibility: PoE is plug and play—devices easily adapt to changing environments, and the entire network can add or subtract devices without interruption.

Scalability: A PoE network can be scaled up easily to add more fixtures in different rooms or locations.

Rules: The IEEE 802.3 standard has a complete description of what can and can't be done, This facilitate the decision making on how a 2inspire system can be put together.

A maximum of 100M or 328ft of uninterrupted cable can be used between the power source and the fixture. If longer length is needed, an in-line POE injector or switch can be used. Passive CAT5 junction couplers **should be avoided**.

Typical setup

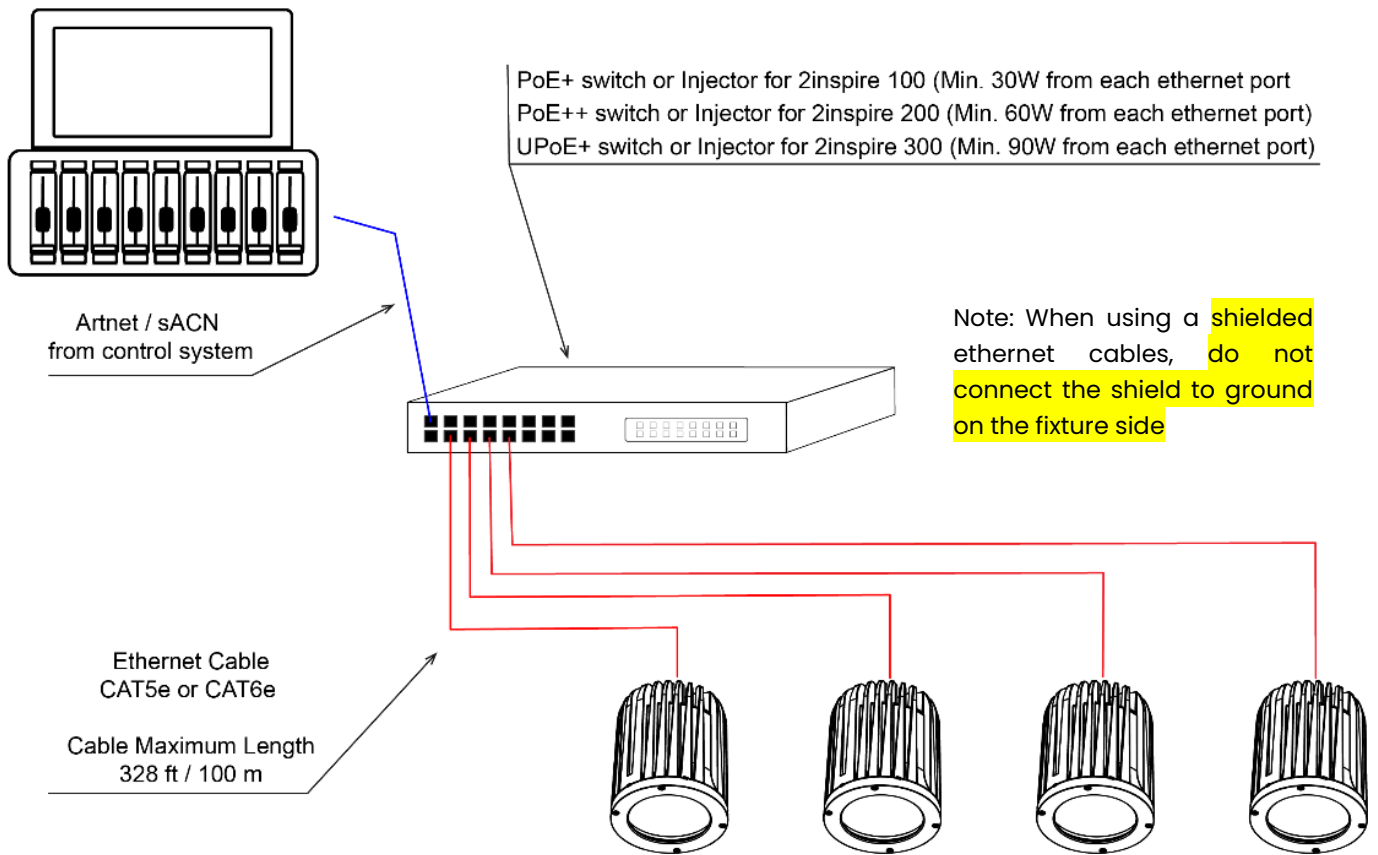

Power (PoE)

Connect the DMX controller to a PoE Injector or an appropriate PoE Switch, or directly to the Chroma-Q® 2inspire™ PSE input using an Ethernet CAT5e or CAT6e cable.

Connect the PoE Injector or appropriate PoE Switch or Chroma-Q® 2inspire™ PSE to the fixture using an Ethernet CAT5e or CAT6e cable.

Power up the PoE Injector or appropriate PoE Switch or Chroma-Q® 2inspire™ PSE, and DMX controller.

Note: Not all Ethernet PoE switches can handle rapid changes in power demand. Some switches can easily manage a steady, constant load, but they may struggle when the power needed by the fixture changes quickly, such as when adjusting the fixture's intensity. This can cause issues with power delivery even if the switch performs well under constant load. It's important to consider both steady load performance and how well the switch handles quick changes in power requirements when selecting a PoE switch for fixtures.

Allow sufficient time for the devices to power up and initialize. >1m

Utilize an RDM-capable device or software to configure the fixture settings and assign the desired address. ([See RDM section](#))

Take control of the fixture's light colors and intensity by using Art-Net™ or sACN protocols. [See DMX layout section](#)

Mounting

The 2inspire™ 100 / 200 / 300 comes with a M5 X 0.8 tapped hole for mounting.

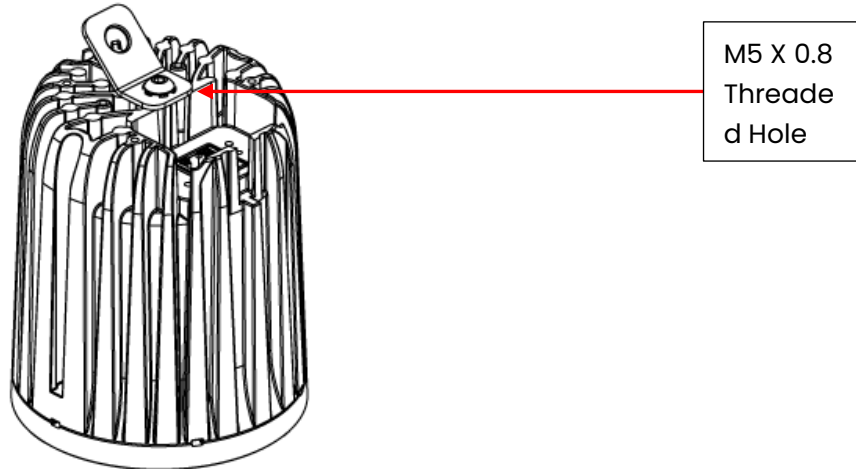

It is crucial to always secure the fixture with the safety L bracket (1509-0165 for black fixture/ 1509-0166 for white fixture) and use safety wire or chain for proper installation. Additionally, it is highly important to use the supplied eyebolt specifically designed for the fixture.

Furthermore, alternative mounting options, including Wall Mount, Yoke, Pendant Ceiling Mount, and Blind Ceiling Mount kits, are available.

For more information on these mounting options, kindly consult your local representative or visit the Chroma-Q® website.

Optional Mounting Kits or accessories for 2inspire™100

Picture	PART NUMBER: Description
	CQ1509-9001 2inspire Wall Mount Short Black CQ1509-9002 2inspire Wall Mount Short White
	CQ1509-9011 2inspire Pendant Mount Kit (W/O Stem, W/O Yoke) Black CQ1509-9012 2inspire Pendant Mount Kit (W/O Stem, W/O Yoke) White CQ1509-9016 2inspire Pendant Stem 1ft, 300mm Black CQ1509-9017 2inspire Pendant Stem 1ft, 300mm White CQ1509-9021 2inspire Pendant Stem 2ft, 600mm Black CQ1509-9022 2inspire Pendant Stem 2ft, 600mm White CQ1509-9026 2inspire Pendant Stem 3ft, 900mm Black CQ1509-9027 2inspire Pendant Stem 3ft, 900mm White
	CQ1509-9106 2inspire 100 Yoke Black* CQ1509-9107 2inspire 100 Yoke White*
	CQ1509-9111 2inspire 100 Shroud for Pendant Mount Black ** CQ1509-9112 2inspire 100 Shroud for Pendant Mount White **
	CQ1509-9116 2inspire 100 Blind Ceiling Mount 0o Black CQ1509-9117 2inspire 100 Blind Ceiling Mount 0o White CQ1509-9118 2inspire 100 Blind Ceiling Mount Recessed 0o Black CQ1509-9119 2inspire 100 Blind Ceiling Mount Recessed 0o White
	CQ1509-9136 2inspire 100 Honeycomb Louver Black CQ1509-9137 2inspire 100 Honeycomb Louver White CQ1509-9141 2inspire 100 Barndoor Black CQ1509-9142 2inspire 100 Barndoor White CQ1509-9146 2inspire 100 Snoot Black CQ1509-9147 2inspire 100 Snoot White CQ1509-9151 2inspire 100 Medium diffusion (pack of 10) CQ1509-9156 2inspire 100 Wide diffusion (pack of 10) CQ1509-9161 2inspire 100 Extra wide diffusion (pack of 10) CQ1509-9166 2inspire 100 asymmetrical diffusion (pack of 10) CQ1509-9171 2inspire 100 Gel Holder C Ring Black (pack of 10) CQ1509-9172 2inspire 100 Gel Holder C Ring White (pack of 10)

* For Pendant Mounting with yoke, the following Kits will be needed

Yoke (CQ1509-9106 or CQ1509-9107)

Pendant Mount Kit (CQ1509-9011 or CQ1509-9012)

Pendant Stem (combination of "CQ1509-9016, CQ1509-9021 & CQ1509-9026," or "CQ1509-9017, CQ1509-9022 & CQ1509-9027")





** For Pendant with Shroud Mounting, the following Kits will be needed

Shroud for Pendant Mount (CQ1509-9111 or CQ1509-9112)

Pendant Mount Kit (CQ1509-9011 or CQ1509-9012)

Pendant Stem (combination of "CQ1509-9016, CQ1509-9021 & CQ1509-9026," or "CQ1509-9017, CQ1509-9022 & CQ1509-9027")

Optional Mounting Kits or accessories for 2inspire™ 200

Picture	PART NUMBER: Description
	CQ1509-9001 2inspire Wall Mount Short Black CQ1509-9002 2inspire Wall Mount Short White
	CQ1509-9011 2inspire Pendant Mount Kit (W/O Stem, W/O Yoke) Black CQ1509-9012 2inspire Pendant Mount Kit (W/O Stem, W/O Yoke) White CQ1509-9016 2inspire Pendant Stem 1ft, 300mm Black CQ1509-9017 2inspire Pendant Stem 1ft, 300mm White CQ1509-9021 2inspire Pendant Stem 2ft, 600mm Black CQ1509-9022 2inspire Pendant Stem 2ft, 600mm White CQ1509-9026 2inspire Pendant Stem 3ft, 900mm Black CQ1509-9027 2inspire Pendant Stem 3ft, 900mm White
	CQ1509-9206 2inspire 200 Yoke Black* CQ1509-9207 2inspire 200 Yoke White*
	CQ1509-9211 2inspire 200 Shroud for Pendant Mount Kit Black** CQ1509-9212 2inspire 200 Shroud for Pendant Mount Kit White**
	CQ1509-9216 2inspire 200 Blind Ceiling Mount 0o Black CQ1509-9217 2inspire 200 Blind Ceiling Mount 0o White CQ1509-9218 2inspire 200 Blind Ceiling Mount Recessed 0o Black CQ1509-9219 2inspire 200 Blind Ceiling Mount Recessed 0o White CQ1509-9221 2inspire 200 Blind Slant Ceiling Mount 0o Black CQ1509-9222 2inspire 200 Blind Slant Ceiling Mount 0o White CQ1509-9226 2inspire 200 Blind Slant Ceiling Mount 0o - 25o Black CQ1509-9227 2inspire 200 Blind Slant Ceiling Mount 0o - 25o White CQ1509-9231 2inspire 200 Blind Slant Ceiling Mount 25o - 45o Black CQ1509-9232 2inspire 200 Blind Slant Ceiling Mount 25o - 45o White
	CQ1509-9236 2inspire 200 Honeycomb Louver Black CQ1509-9237 2inspire 200 Honeycomb Louver White CQ1509-9241 2inspire 200 Barndoor Black CQ1509-9242 2inspire 200 Barndoor White CQ1509-9246 2inspire 200 Snoot Black CQ1509-9247 2inspire 200 Snoot White CQ1509-9251 2inspire 200 Medium diffusion (pack of 10) CQ1509-9256 2inspire 200 Wide diffusion (pack of 10) CQ1509-9261 2inspire 200 Extra wide diffusion (pack of 10) CQ1509-9266 2inspire 200 asymmetrical diffusion (pack of 10) CQ1509-9271 2inspire 200 Gel Holder C Ring Black (pack of 10) CQ1509-9272 2inspire 200 Gel Holder C Ring White (pack of 10)

* For Pendant Mounting with yoke, the following Kits will be needed





Yoke (CQ1509-9206 or CQ1509-9207), Pendant Mount Kit (CQ1509-9011 or CQ1509-9012), Pendant Stem (combination of "CQ1509-9016, CQ1509-9021 & CQ1509-9026," or "CQ1509-9017, CQ1509-9022 & CQ1509-9027")

** For Pendant with Shroud Mounting, the following Kits will be needed

Shroud for Pendant Mount (CQ1509-9211 or CQ1509-9212), Pendant Mount Kit (CQ1509-9011 or CQ1509-9012)

Pendant Stem (combination of "CQ1509-9016, CQ1509-9021 & CQ1509-9026," or "CQ1509-9017, CQ1509-9022 & CQ1509-9027")

Optional Mounting Kits or accessories for 2inspire™ 300

Picture	PART NUMBER: Description
	CQ1509-9001 2inspire Wall Mount Short Black CQ1509-9002 2inspire Wall Mount Short White
	CQ1509-9011 2inspire Pendant Mount Kit (W/O Stem, W/O Yoke) Black CQ1509-9012 2inspire Pendant Mount Kit (W/O Stem, W/O Yoke) White CQ1509-9016 2inspire Pendant Stem 1ft, 300mm Black CQ1509-9017 2inspire Pendant Stem 1ft, 300mm White CQ1509-9021 2inspire Pendant Stem 2ft, 600mm Black CQ1509-9022 2inspire Pendant Stem 2ft, 600mm White CQ1509-9026 2inspire Pendant Stem 3ft, 900mm Black CQ1509-9027 2inspire Pendant Stem 3ft, 900mm White
	CQ1509-9306 2inspire 300 Yoke Black* CQ1509-9307 2inspire 300 Yoke White*
	CQ1509-9311 2inspire 300 Shroud for Pendant Mount Kit Black** CQ1509-9312 2inspire 300 Shroud for Pendant Mount Kit White**
	CQ1509-9316 2inspire 300 Blind Ceiling Mount 0o Black CQ1509-9317 2inspire 300 Blind Ceiling Mount 0o White CQ1509-9318 2inspire 300 Blind Ceiling Mount Recessed 0o Black CQ1509-9319 2inspire 300 Blind Ceiling Mount Recessed 0o White CQ1509-9321 2inspire 300 Blind Slant Ceiling Mount 0o Black CQ1509-9322 2inspire 300 Blind Slant Ceiling Mount 0o White CQ1509-9326 2inspire 300 Blind Slant Ceiling Mount 0o - 25o Black CQ1509-9327 2inspire 300 Blind Slant Ceiling Mount 0o - 25o White CQ1509-9331 2inspire 300 Blind Slant Ceiling Mount 25o - 45o Black CQ1509-9332 2inspire 300 Blind Slant Ceiling Mount 25o - 45o White
	CQ1509-9336 2inspire 300 Honeycomb Louver Black CQ1509-9337 2inspire 300 Honeycomb Louver White CQ1509-9341 2inspire 300 Barndoor Black CQ1509-9342 2inspire 300 Barndoor White CQ1509-9346 2inspire 300 Snoot Black CQ1509-9347 2inspire 300 Snoot White CQ1509-9351 2inspire 300 Medium diffusion (pack of 10) CQ1509-9356 2inspire 300 Wide diffusion (pack of 10) CQ1509-9361 2inspire 300 Extra wide diffusion (pack of 10) CQ1509-9366 2inspire 300 asymmetrical diffusion (pack of 10) CQ1509-9371 2inspire 300 Gel Holder C Ring Black (pack of 10) CQ1509-9372 2inspire 300 Gel Holder C Ring White (pack of 10)

* For Pendant Mounting with yoke, the following Kits will be needed

Yoke (CQ1509-9306 or CQ1509-9307), Pendant Mount Kit (CQ1509-9011 or CQ1509-9012), Pendant Stem (combination of "CQ1509-9016, CQ1509-9021 & CQ1509-9026," or "CQ1509-9017, CQ1509-9022 & CQ1509-9027")

** For Pendant with Shroud Mounting, the following Kits will be needed, Shroud for Pendant Mount (CQ1509-9311 or CQ1509-9312), Pendant Mount Kit (CQ1509-9011 or CQ1509-9012)

Pendant Stem (combination of "CQ1509-9016, CQ1509-9021 & CQ1509-9026," or "CQ1509-9017, CQ1509-9022 & CQ1509-9027")

2inspire™ Pendant Mount Kit choices

To have a complete pendant kit, three items need to be ordered, select one in each of the below sections (A, B and C)

Section	Part Number	Description
A	CQ1509-9011	2inspire PoE Series Pendant Mount Kit (W/O Stem, W/O Yoke) Black
	CQ1509-9012	2inspire PoE Series Pendant Mount Kit (W/O Stem, W/O Yoke) White
B	CQ1509-9016	2inspire PoE Series Pendant Stem 1ft, 300mm Black
	CQ1509-9017	2inspire PoE Series Pendant Stem 1FT, 300mm White
	CQ1509-9021	2inspire PoE Series Pendant Stem 2FT, 600mm Black
	CQ1509-9022	2inspire PoE Series Pendant Stem 2FT, 600mm White
	CQ1509-9026	2inspire PoE Series Pendant Stem 3FT, 900mm Black
	CQ1509-9027	2inspire PoE Series Pendant Stem 3FT, 900mm White
	CQ1509-0081	2inspire PoE Series Pendant Stem Extension Black
	CQ1509-0082	2inspire PoE Series Pendant Stem Extension White
C	CQ1509-9106	2inspire 100 Yoke Black
	CQ1509-9107	2inspire 100 Yoke White
	CQ1509-9206	2inspire 200 Yoke Black
	CQ1509-9207	2inspire 200 Yoke White
	CQ1509-9306	2inspire 300 Yoke Black
	CQ1509-9307	2inspire 300 Yoke White
Or		
C	CQ1509-9111	2inspire 100 Shroud for Pendant Mount Kit Black
	CQ1509-9112	2inspire 100 Shroud for Pendant Mount Kit White
	CQ1509-9211	2inspire 200 Shroud for Pendant Mount Kit Black
	CQ1509-9212	2inspire 200 Shroud for Pendant Mount Kit White
	CQ1509-9311	2inspire 300 Shroud for Pendant Mount Kit Black
	CQ1509-9312	2inspire 300 Shroud for Pendant Mount Kit White

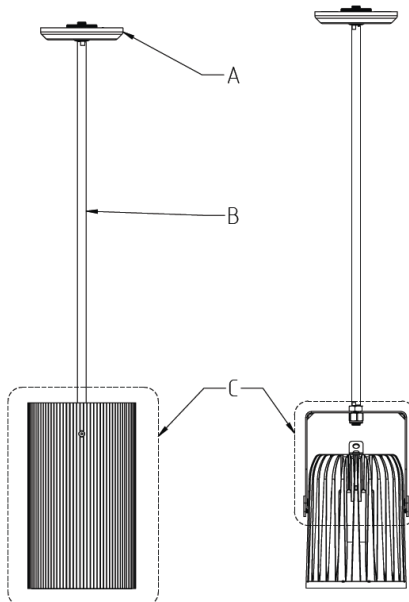

www.chroma-q.com

Beam control, Diffusion

The 2inspire™100 / 200 / 300 comes with a native narrow beam angle.

A set of optional diffusion filters is available to expand the fixture coverage.

Each diffusion filter type has a set of notches “L” to identify, see below table

Fixture	Filter Diameter	Native	Asymmetrical	Medium	Wide	Extra Wide
Notch(es) count			L	LL	LLL	LLLL
2inspire™100	69mm	21° 	22X34° 	34° 	76° 	60°/116°
2inspire™200	92mm	19° 	22X34° 	40° 	52° 	52°/116°
2inspire™300	121mm	26.5° 	32X42° 	42° 	84° 	104°

**The Extra-Wide diffusion has more lateral light emission, ideal when light bouncing on adjacent wall(s) is desired.

Photometric and IES Data

Photometric and IES files are available on the [2inspire Downloads](#) section

www.chroma-q.com

Installing the diffusion filter.

IP 20 version

The 2inspire™ 100 / 200 / 300 IP 20 comes with their respective “Gel holder C ring”.
First, insert the diffusion filter, it might need to be slightly bent to insert.
Next, insert the C ring to lock the diffusion filter in place.

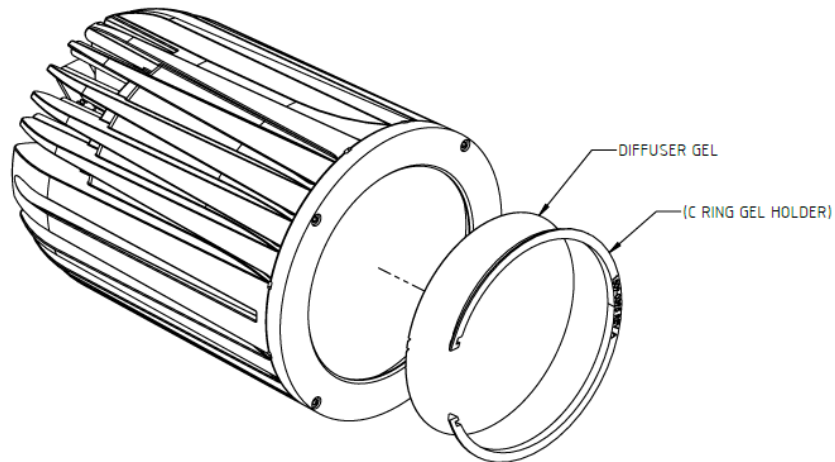

Figure 1 – IP20

IP 65 version

To install or change a diffusion filter on the IP 65 version, the front bezel must be removed and the diffusion gel inserted between the glass and the lens. Only the Chroma-Q original diffusion gel are approved to be used.

The four screws on bezel need to be reinstalled with a torque of 1.45 Nm (12.83 in-lb) for 2inspire™ 100 and 1.6 Nm (14 in-lb) for 2inspire™ 200/300 to ensure complete tightness preventing any environmental exposure of the fixtures.

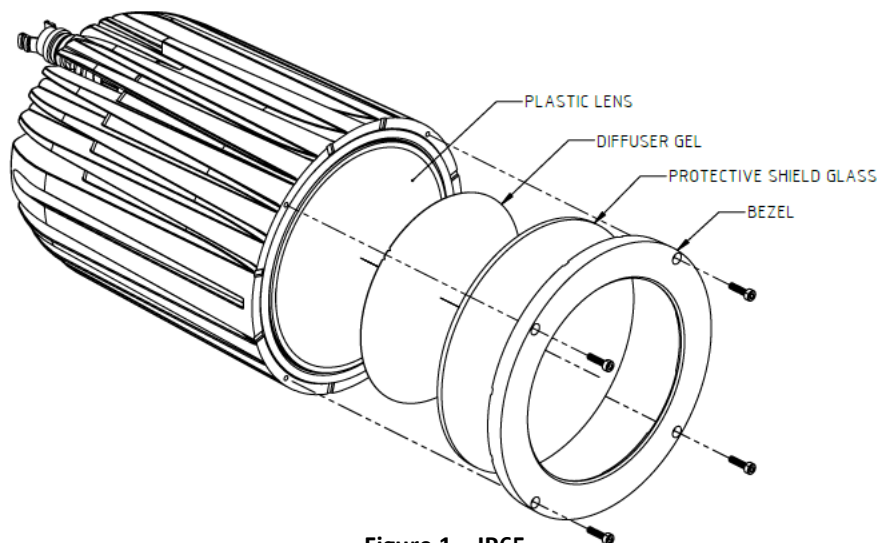
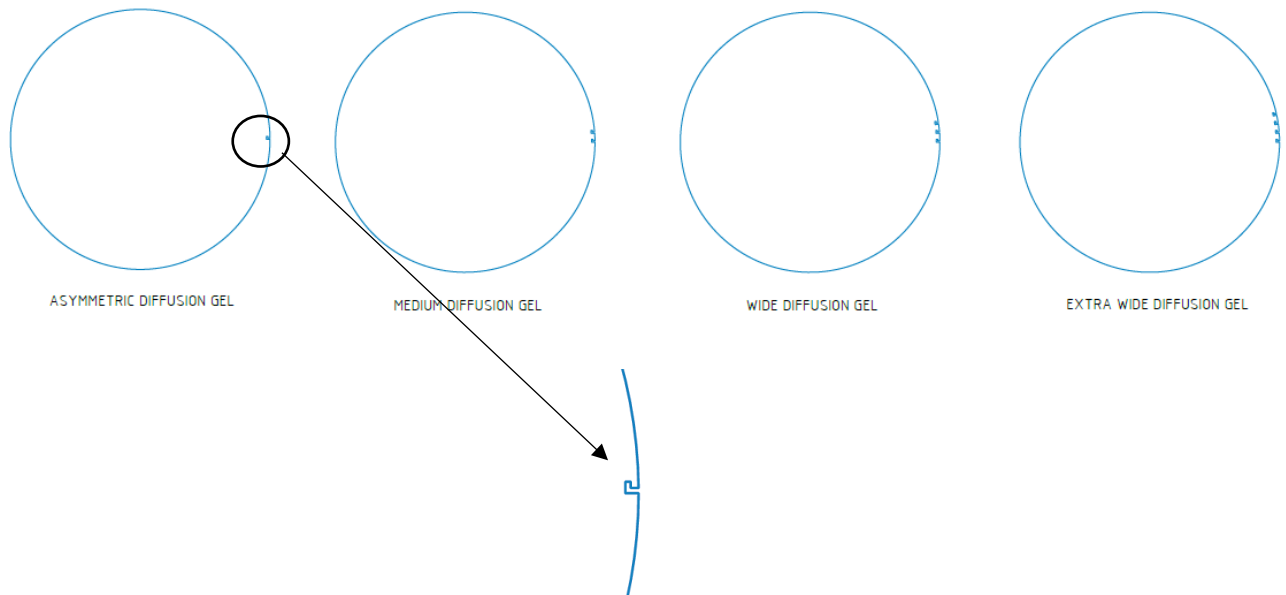

Figure 1 – IP65

www.chroma-q.com

Patterns and Orientation for diffusers



L notch pointing upwards

The shiny surface should be facing down towards the Lens of the fixture

Controlling the 2inspire™

The 2inspire™ 100 / 200 / 300 fixtures offer robust control options through Art-Net™ or sACN over Ethernet, utilizing a PoE switch, PoE injector, or the Chroma-Q® 2inspire™ PSE.

Art-Net™ or sACN?

Choosing the right communication protocol is critical to ensuring a smooth and responsive installation.

While Art-Net™ is widely known and utilized, it may not always be the best choice. When Art-Net™ is broadcast over a network, and more than 12 universes are being broadcast, the fixture's processor must capture all universes and then filter out the unnecessary data. This filtering process can be time-consuming and may result in delayed fixture responses if the processor becomes overwhelmed.

One solution for handling more than 12 universes is to switch from Art-Net™ broadcast to Art-Net™ Unicast. In this setup, the fixture receives only the data it specifically requires, reducing processing load.

However, a more efficient option is to use sACN, assuming the control source supports it. When sACN is employed, the fixture uses IGMP snooping to request only the necessary data. This approach ensures more efficient data handling, provided the network switch or PoE source also supports IGMP snooping.

Changing the fixture protocol (Art-Net™/sACN), Personality, DMX address, Universe

To change the various settings of the 2inspire™ including the communication protocol of the fixture, different RDM tools can be used. In this example we are using the free to download Windows™ software [Singularity™ DMX-Workshop™](#).

Set the PC Ethernet Port 2.0.0.1 Subnet 255.0.0.0

Using DMX-Workshop with 2inspire™

DMX-Workshop™ is a powerful software tool developed by [Singularity](#) for managing, testing, and configuring DMX and RDM (Remote Device Management) lighting networks. It is primarily used by lighting technicians and engineers for diagnosing and troubleshooting complex lighting setups, such as those used in theaters, concerts, and architectural lighting systems

Start DMX-Workshop™

- o Select the NIC that is on 2.0.0.1 and click OK

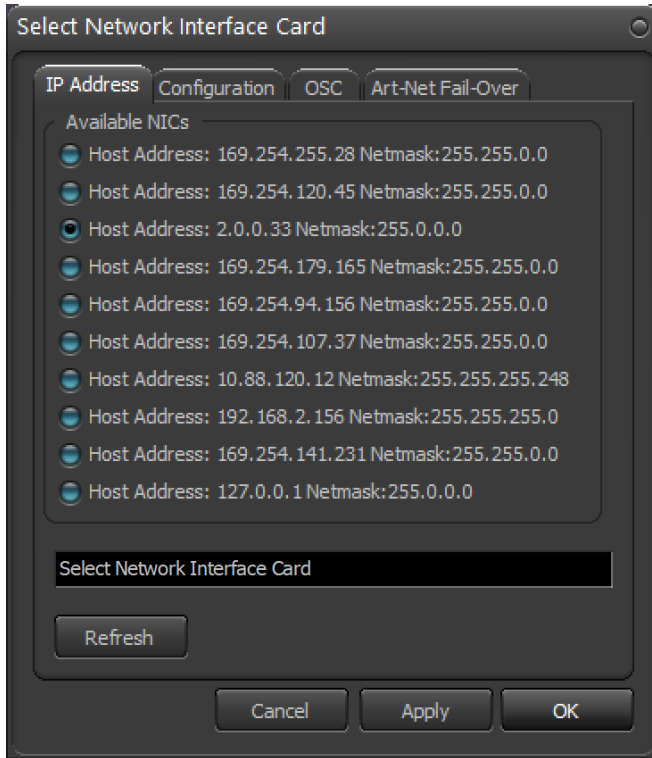

- o Click on Node List

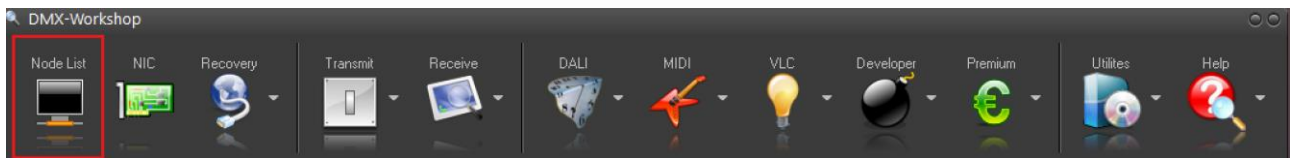

- o The Node List window should show all the discovered fixtures, if there are duplicated IP addresses, click on [Rebuild]

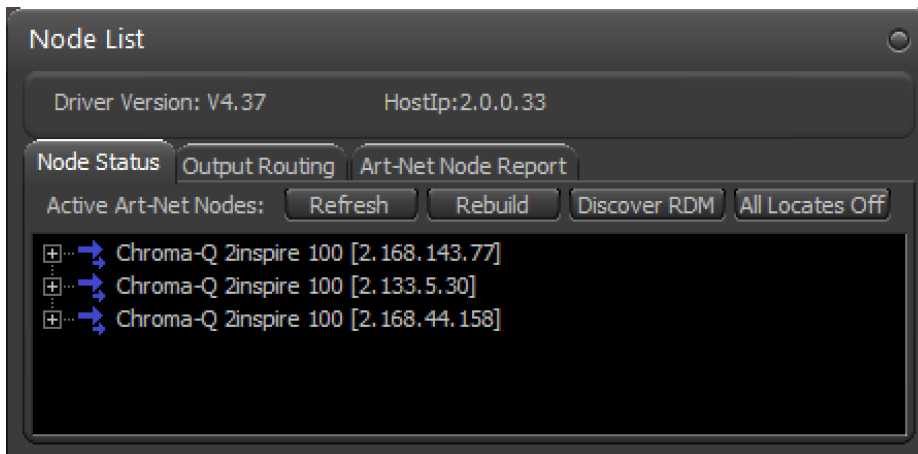

- o Expand a fixture tree list by clicking on the '+'s until all of them are expanded

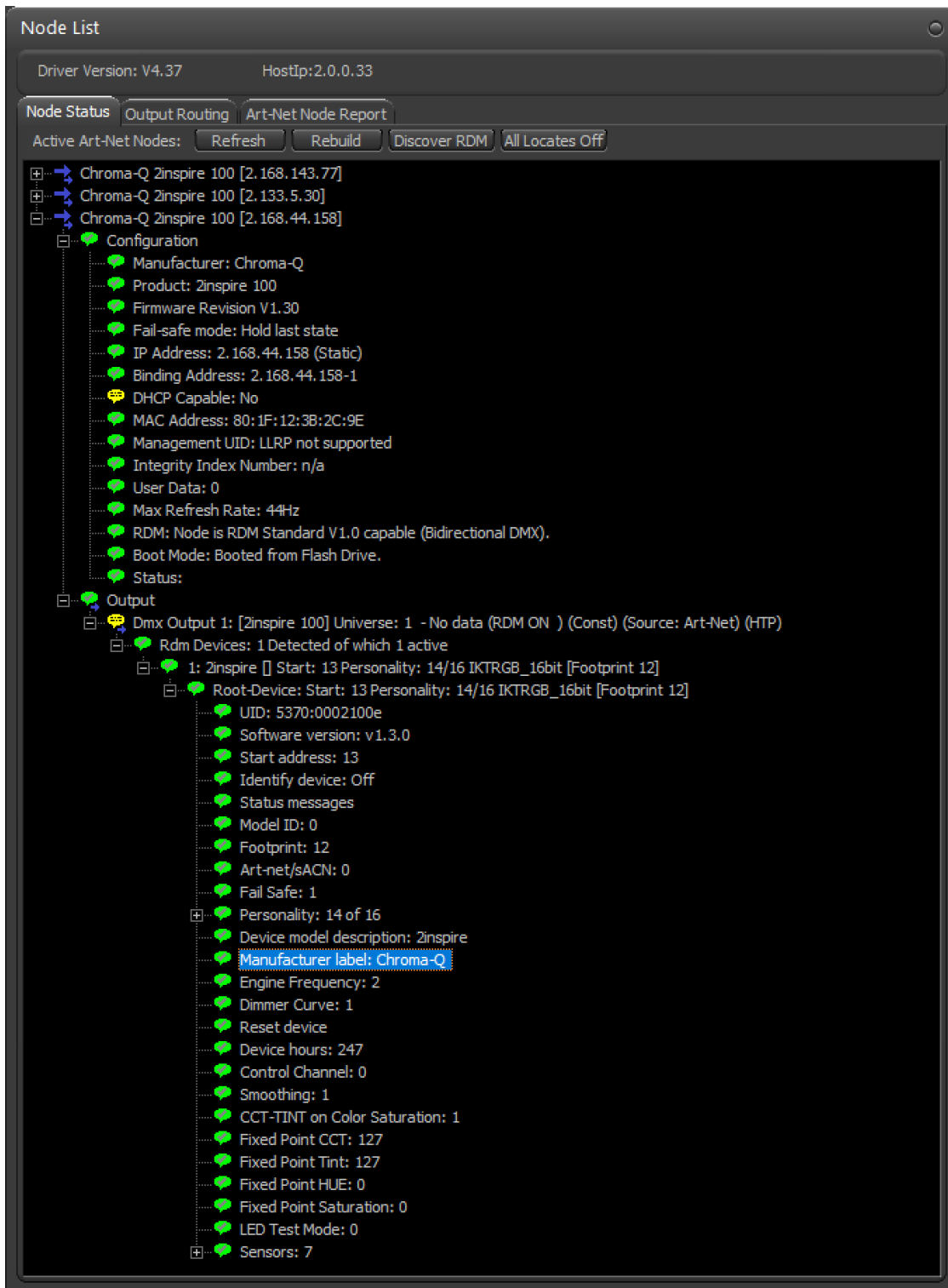

Setting the Protocol Art-Net™ or sACN

There are two ways to change the protocol,

- o Right-Click on DMX Output 1: and click on Output Protocol, and select the designer protocol.

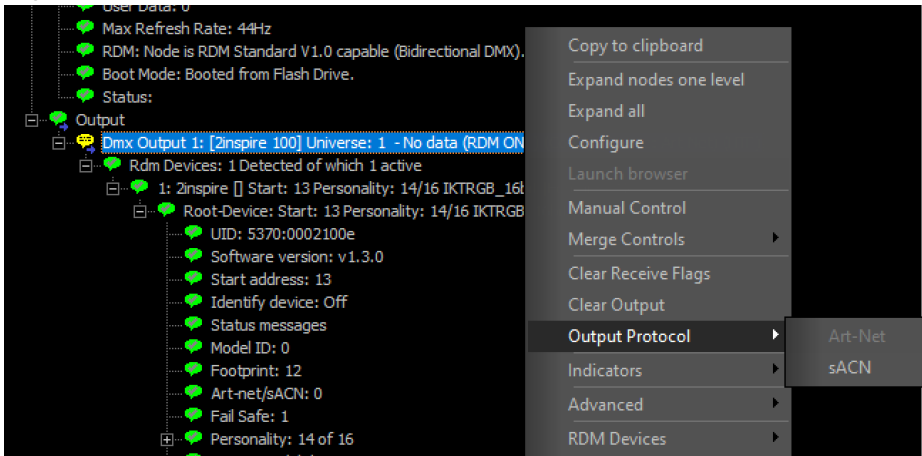

- o Right-Click on Art-Net/sACN :X and select click on Set Art-Net/sACN

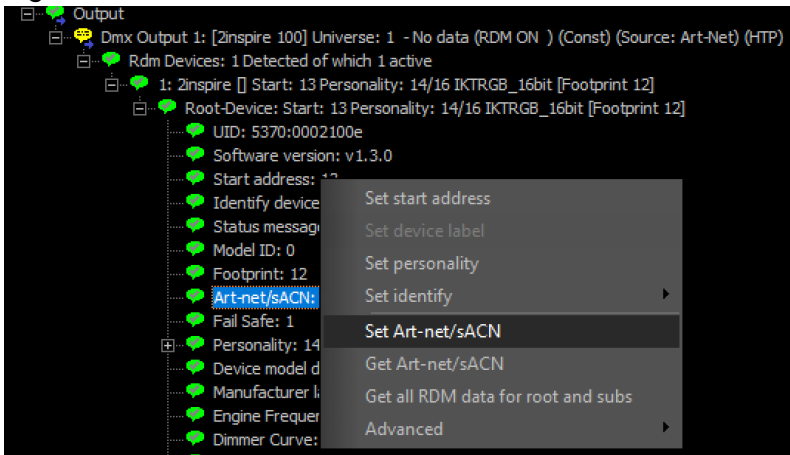

- o Set the RDM PID value to 0 for Art-Net or 1 for sACN and press Set

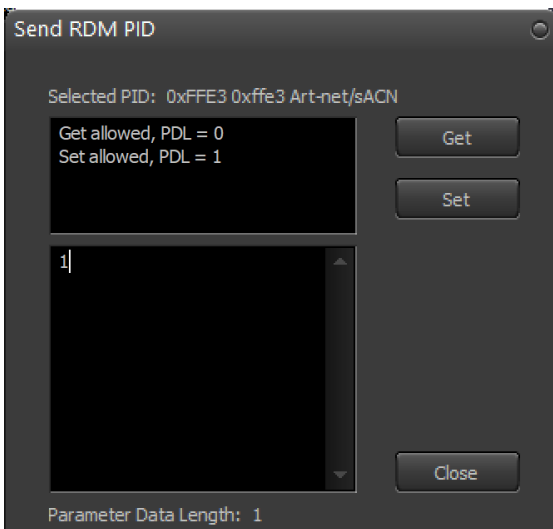

Setting the DMX address,

- o Right-Click on Start address>Set start address and enter the desired value 1 to 512

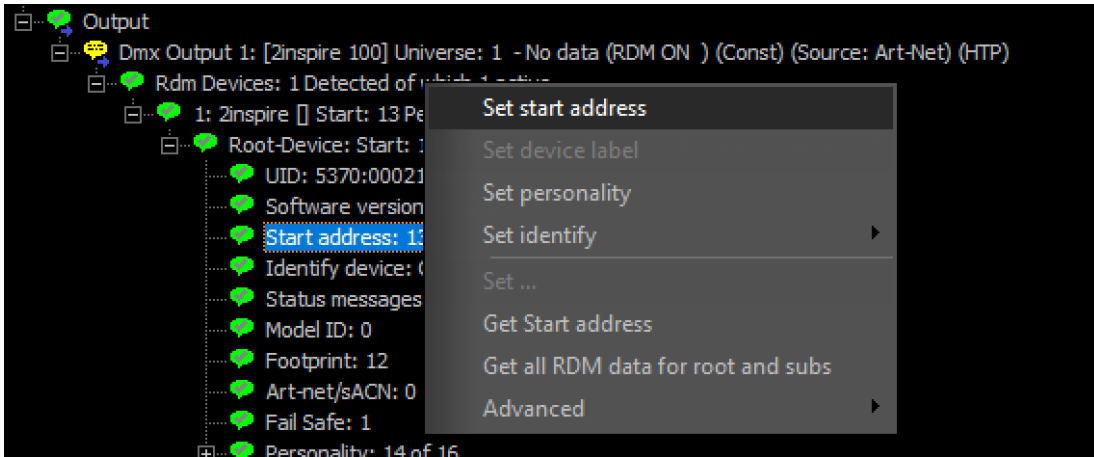

Setting the Universe and device name

- o Right-Click on the "DMX Output 1:..." and click Configure

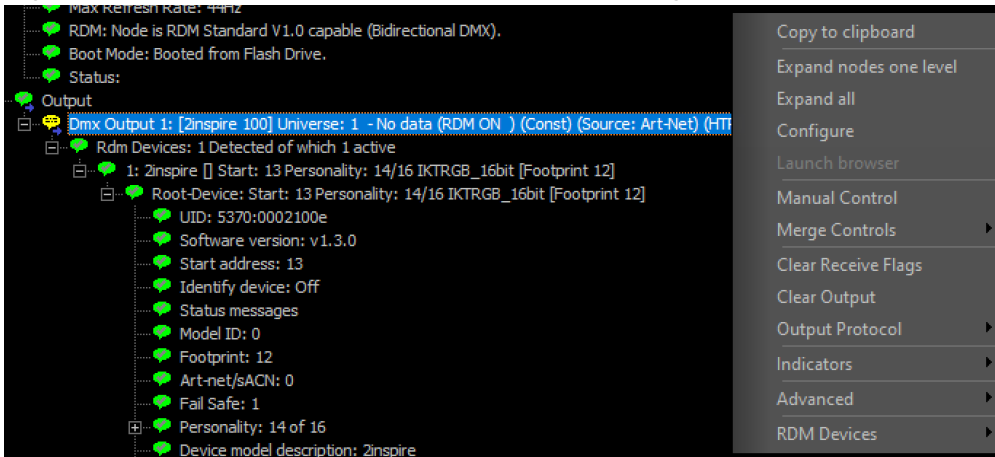

- o In the Configure window, the Universe and Device name can be set.

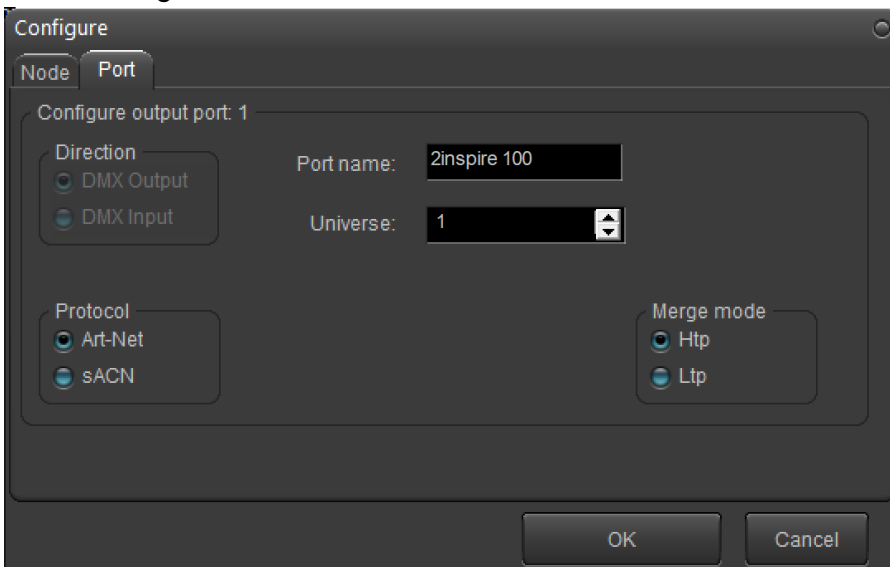

Identifying fixture remotely

When multiple fixtures are connected to a system, locating a specific fixture in DMX-Workshop™ can be challenging. However, there is an option to identify a fixture by sending a command to make it flash momentarily. To do this:

Right-click on the fixture in the list or on any entry corresponding to that fixture. Select Indicator from the context menu. Click on Identify.

This action will make the selected fixture flash, helping you quickly locate it in the setup. This feature is especially useful for large or complex lighting systems where visual identification can save time and reduce errors.

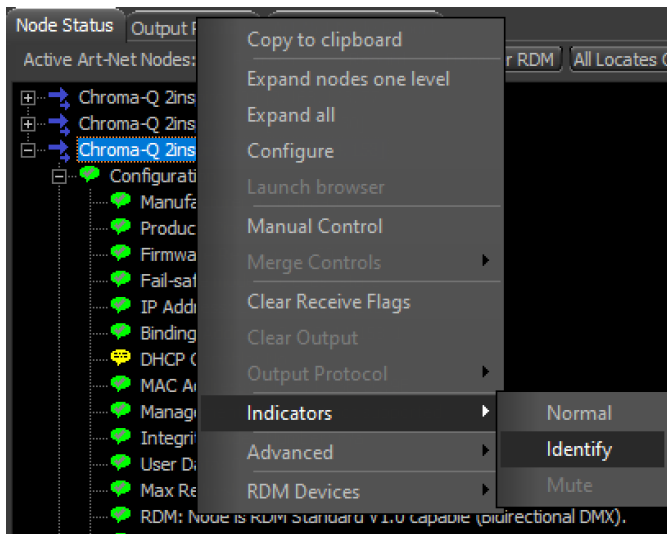

Changing IP Address and Subnet Mask

The 2inspire fixtures come pre-configured with an IP address in the 2.x.x.x range and a subnet of 255.0.0.0. Each 2inspire unit is assigned a unique IP address from the factory, eliminating the need to change IP addresses as long as the 2.x.x.x range is suitable for the user's network configuration. This standard setup simplifies initial deployment and helps prevent address conflicts, making it easier to integrate the fixtures into a compatible network without additional configuration.



Changing the IP address and subnet of a fixture is possible but requires careful planning and execution. If the IP address or subnet is changed and the user forgets the new configuration, the fixture must be reset to its factory default settings. This reset process necessitates physical access to the fixture, which is an important factor to consider, especially if the fixtures are installed in hard-to-reach places, such as ceilings. Proper planning and documentation of network settings are essential to avoid unexpected difficulties with access and configuration. (See [Reset / Test Switch](#))

Setting the IP address, using [Singularity™ DMX-Workshop™](#) .

Right-click on the fixture, click on Advanced and then Configure IP Address

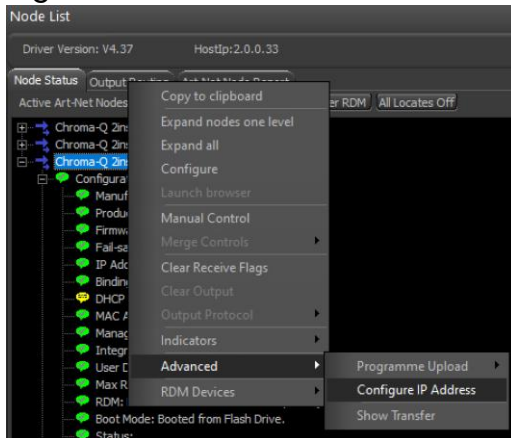

The Configure Node IP Settings window should appear

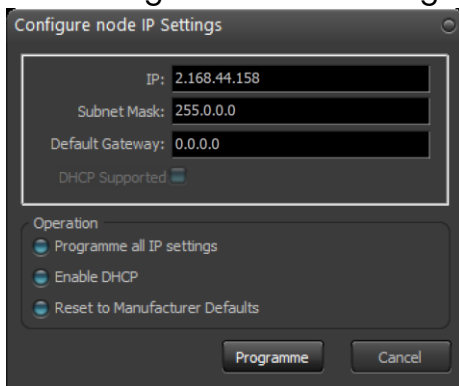

Set the new IP address and subnet, select Programme all IP settings



(Make sure to note or remember these settings, as they are essential for the next steps.)

If the IP range or subnet differs from the current connection, the fixture will not appear in DMX-Workshop until the PC network adapter is configured to match the new range.

Important: DHCP is not supported on 2inspire.

Additional RDM Commands

There are many more RDM commands specific to the 2inspire, see the [RDM Custom Commands table](#)

Understanding the new Chroma-Q Gen3 color engine control

The 2inspire™ utilizes the latest Chroma-Q Gen3™ Color Engine control. In this new algorithm, color control is fully abstracted from the direct control of the LEDs. This means that the Red, Green, and Blue controls do not directly control the corresponding LEDs but rather control the position of the color point throughout the entire color space that the fixture can cover. The 2inspire™ algorithm has been designed to always provide the best possible combination of all five LEDs sources: Red, Green, Blue, Warm White, and Cold White.

The best color and white points are easily achievable by using Red, Green, and Blue control. For example, if the selected control Personality is the default IKTRGB,

- Intensity set to 100%-(255)
- CCT and Tint in a neutral position at 50%-(127)
- and Red, Green, and Blue at 100%-(255)

The result white and that white point is determined by the CCT(K) and Tint(T) controls.

The CCT (Correlated Color Temperature) ranges from warm 2400 to cold 6500 Kelvin (K). The Tint controls the green/magenta axis; a higher value results in a greener output, while a lower value yields a pinker tone.

By default, the CCT and Tint will also have an effect on saturated colors, for example if only the Red channel is at 100%-(255) but the CCT and/or Tint control are different then 127 (neutral) the resulting red will be altered.

In [RDM](#) or using the [extended DMX control channel](#), it is possible to disable/enable this function.

When a control personality does not have a CCT(K) and/or a Tint, it is possible to define what these values are using the RDM settings ([SEE RDM](#) for more on this)

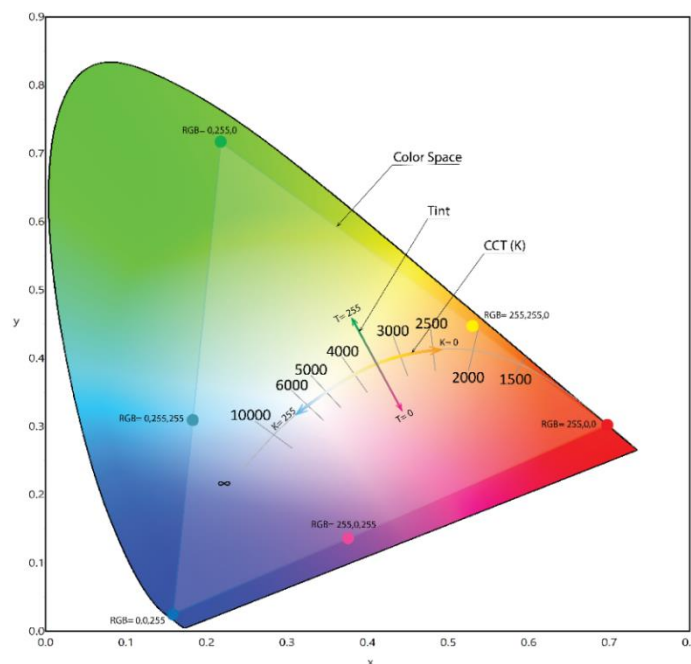

www.chroma-q.com

Control Personalities

Personality Name	Description
I	**Single channel Intensity
IK	**Intensity and CCT
IKT	Intensity, CCT, Tint
RGB	**RGB+magic white
IRGB	** Intensity, RGB+magic white
IHS	**Intensity, Hue(color) and Saturation (from white to color)
IKTRGB	Intensity, CCT, Tint, RGB+magic white
IKTHS	Intensity, CCT, Tint, Hue, Saturation+magic white
**	The white point is set in RDM (set CCT 0-255 default 127) (set Tint 0-255 default 127) See DMX-CCT table for color temperature values

I - Single channel Intensity: This control Personality uses a single DMX channel to regulate the intensity of the fixture's output. Brightness can be adjusted from 0 (off) to full intensity (255). The white point is set in RDM (set Fixed CCT 0-255 default 127 - 4440K) (set Fixed Tint 0-255 default 127)

IK - Intensity and CCT: This Personality uses two DMX channels. The first controls intensity, while the second adjusts the color temperature in Kelvin (CCT). This allows you to manage the brightness of the fixture and the warmth or coolness of its color tone. The white point Tint is set in RDM (set Fixed Tint 0-255 default 127)

IKT - Intensity, CCT, Tint: This Personality expands on the previous by adding a third DMX channel for Tint control. This means you can adjust the intensity, color temperature, and the green-magenta bias (Tint) of the fixture's output.

RGB - RGB+magic white: In this Personality, the fixture uses three DMX channels for Red, Green, and Blue color controls to create a full spectrum of colors. The white point is set in RDM (set Fixed CCT 0-255 default 127 - 4440K) (set Fixed Tint 0-255 default 127)

IRGB - Intensity, RGB+magic white: This Personality adds an Intensity control to the previous RGB Personality. You can manipulate the brightness of the fixture, in addition to its color through the RGB channels. The white point is set in RDM (set Fixed CCT 0-255 default 127 - 4400K) (set Fixed Tint 0-255 default 127)

IHS- Intensity, Hue(color) and Saturation (from white to color): This Personality uses three DMX channels. You can regulate the light's intensity, its hue (the base color), and saturation (the richness or purity of the color). The white point is set in RDM (set Fixed CCT 0-255 default 127- 4440K) (set Fixed Tint 0-255 default 127)

IKTRGB - Intensity, CCT, Tint, RGB+magic white: This Personality is a comprehensive combination of the previous ones. It gives control over intensity, color temperature (CCT), tint (green-magenta bias), and full RGB color control.

IKTRGB - Intensity, CCT, RGB+magic white: This default Personality offers optimal color control for the fixture. It allows for adjustments to intensity, color temperature (CCT), and green-magenta tint, as well as

the full range of colors that the fixture can produce using the RGB control. When all RGB values are set to 100% (255), the fixture will display white light. This setup provides precise and comprehensive color management for various lighting needs.

IKTHS - Intensity, CCT, Tint, Hue, Saturation+magic white: This Personality provides in-depth color control. You can adjust the fixture's intensity, color temperature (CCT), green-magenta tint, the base hue, and the saturation. The white point is set in RDM.

16 bit control: In addition to these standard 8 bit Personalities, all control Personalities can be operated in 16-bit control, providing a greater degree of precision and accuracy. This effectively expands the control resolution from the basic 256 steps (8 bits) to a massive 65,536 steps (16 bits). This is particularly beneficial in applications where precise color mixing, smooth dimming or subtle changes in intensity, hue, or saturation are required. No matter the Personality - be it single channel intensity, color temperature control, or complex RGB mixing - the 16-bit control option delivers superior granular control, enhancing the capabilities of each fixture.

Channel layout

Personality Name	1	2	3	4	5	6	7	8	9	10	11	12
8 bit												
I	I											
IK	I	K										
IKT	I	K	T									
RGB	R	G	B									
IRGB	I	R	G	B								
IHS	I	H	S									
IKTRGB	I	K	T	R	G	B						
IKTHS	I	K	T	H	S							
16 bit**												
I - 16bit	I	i										
IK - 16bit	I	i	K	k								
IKT - 16bit	I	i	K	k	T	t						
RGB - 16bit	R	r	G	g	B	b						
IRGB - 16bit	I	i	R	r	G	g	B	b				
IHS- 16bit	I	i	H	h	S	s						
IKTRGB - 16bit	I	i	K	k	T	t	R	r	G	g	B	b
IKTHS - 16bit	I	i	K	k	T	t	H	h	S	s		

Control*	C
-----------------	---

*Control parameter is only present when Control option is enabled in RDM settings and always the last channel

**16 bit parameters are using two 8 bit control channel combined together to create a 16 bit value. The first channel is the MSB (Most Significant Bit) and the second channel is the LSB (Least Significant Bit)

Chroma-Q® 2inspire™100/200/300 (I) Intensity Personality

I - Single channel Intensity Personality**: This control personality uses a single DMX channel to regulate the intensity of the fixture's output. Brightness can be adjusted from 0 (off) to full intensity (255).

8-bit

Channel	Value	Function	Fade Status	Default Value
1		Intensity		
	0 - 255	Minimum → Maximum Intensity	Fade	0
2**		Extended Controls		
	0 - 255	See Control channel table for details	Snap	0

16-bit

Channel	Value	Function	Fade Status	Default Value
1-2		Intensity		
	0 - 65535	Minimum → Maximum Intensity	Fade	0
3**		Extended Controls		
	0 - 255	See Control channel table for details	Snap	0

Note: The white point is set in RDM (set Fixed CCT 0-255 default 127 - 4440K) (set Fixed Tint 0-255 default 127)

** An additional control channel can be enabled and will always be positioned as the last channel and it is 8-bit even when 16-bit personality is set.

Chroma-Q® 2inspire™100/200/300 (IK) Intensity and CCT Personality

IK - Intensity and CCT: This personality uses two DMX channels. The first controls intensity, while the second adjusts the color temperature in Kelvin (CCT). This allows you to manage the brightness of the fixture and the warmth or coolness of its color tone.

8-bit

Channel	Value	Function	Fade Status	Default Value
1		Intensity		
	0 - 255	Minimum → Maximum Intensity	Fade	0
2		Corelated Color Temperature (CCT in Kelvin)		
	0	2400K	Fade	127
	25	2800K		
	50	3200K		
	75	3600K		
	100	4000K		
	127	4440K(Neutral)		
	150	4800K		
	175	5200K		
	200	5600K		
	225	6000K		
	255	6500K		
3**		Extended Controls		
	0 - 255	See Control channel table for details	Snap	0

16-bit

Channel	Value	Function	Fade Status	Default Value
1-2		Intensity		
	0 - 65535	Minimum → Maximum Intensity	Fade	0
3-4		Corelated Color Temperature (CCT in Kelvin)		
	0	2400K	Fade	32767
	6400	2800K		
	12800	3200K		
	19200	3600K		
	25600	4000K		
	32767	4440K(Neutral)		
	38400	4800K		
	44800	5200K		
	51200	5600K		
	57600	6000K		
	65535	6500K		
5**		Extended Controls		
	0 - 255	See Control channel table for details	Snap	0

Note: The white point Tint is set in RDM (set Tint 0-255 default 127)
 An additional control channel can be enabled and will always be positioned as the last channel and it is 8-bit even when 16-bit personality is set.

**

Chroma-Q® 2inspire™100/200/300 (IKT) Intensity, CCT and Tint Personality

IKT - Intensity, CCT, Tint: This personality expands on the previous by adding a third DMX channel for Tint control. This means you can adjust the intensity, color temperature, and the green-magenta bias (Tint) of the fixture's output.

8-bit

Channel	Value	Function	Fade Status	Default Value
1		Intensity		
	0 - 255	Minimum → Maximum Intensity	Fade	0
2		Corelated Color Temperature (CCT in Kelvin)		
	0	2400K	Fade	127
	25	2800K		
	50	3200K		
	75	3600K		
	100	4000K		
	127	4440K(Neutral)		
	150	4800K		
	175	5200K		
	200	5600K		
225	6000K			
255	6500K			
3		Tint (plus/minus green)		
	0	-2	Fade	127
	127	0 (Neutral)		
255	+2			
4**		Extended Controls		
	0 - 255	See Control channel table for details	Snap	0

16-bit

Channel	Value	Function	Fade Status	Default Value
1-2		Intensity		
	0 - 65535	Minimum → Maximum Intensity	Fade	0
3-4		Corelated Color Temperature (CCT in Kelvin)		
	0	2400K	Fade	32767
	6400	2800K		
	12800	3200K		
	19200	3600K		
	25600	4000K		
	32767	4440K(Neutral)		
	38400	4800K		
	44800	5200K		
	51200	5600K		
57600	6000K			
65535	6500K			
5-6		Tint (plus/minus green)		
	0	-2	Fade	32767
	32767	0 (Neutral)		
65535	+2			
7**		Extended Controls		
	0 - 255	See Control channel table for details	Snap	0

Note:

An additional control channel can be enabled and will always be positioned as the last channel and it is 8-bit even when 16-bit personality is set.

**

Chroma-Q® 2inspire™100/200/300 (RGB) RGB+magic white Personality

RGB – RGB+magic white: In this personality, the fixture uses three DMX channels for Red, Green, and Blue color controls to create a full spectrum of colors. The magic white is set in RDM and can be adjusted for CCT and Tint (default 127 each)

8-bit

Channel	Value	Function	Fade Status	Default Value
1		Red		
	0 - 255	Minimum → Maximum Intensity	Fade	0
2		Green		
	0 - 255	Minimum → Maximum Intensity	Fade	0
3		Blue		
	0 - 255	Minimum → Maximum Intensity	Fade	0
4**		Extended Controls		
	0 - 255	See Control channel table for details	Snap	0

16-bit

Channel	Value	Function	Fade Status	Default Value
1-2		Red		
	0 - 65535	Minimum → Maximum Intensity	Fade	0
3-4		Green		
	0 - 65535	Minimum → Maximum Intensity	Fade	0
5-6		Blue		
	0 - 65535	Minimum → Maximum Intensity	Fade	0
7**		Extended Controls		
	0 - 255	See Control channel table for details	Snap	0

Note: The white point is set in RDM (set Fixed CCT 0-255 default 127 - 4440K) (set Fixed Tint 0-255 default 127)

** An additional control channel can be enabled and will always be positioned as the last channel and it is 8-bit even when 16-bit personality is set.

Chroma-Q® 2inspire™100/200/300 (IRGB) Intensity,RGB+magic white Personality

IRGB - Intensity, RGB+magic white: This personality adds an Intensity control to the previous RGB Personality. You can manipulate the brightness of the fixture, in addition to its color through the RGB channels. The white point is managed in RDM.

8-bit

Channel	Value	Function	Fade Status	Default Value
1		Intensity		
	0 - 255	Minimum → Maximum Intensity	Fade	0
2		Red		
	0 - 255	Minimum → Maximum Intensity	Fade	0
3		Green		
	0 - 255	Minimum → Maximum Intensity	Fade	0
4		Blue		
	0 - 255	Minimum → Maximum Intensity	Fade	0
5**		Extended Controls		
	0 - 255	See Control channel table for details	Snap	0

16-bit

Channel	Value	Function	Fade Status	Default Value
1-2		Intensity		
	0 - 65535	Minimum → Maximum Intensity	Fade	0
3-4		Red		
	0 - 65535	Minimum → Maximum Intensity	Fade	0
5-6		Green		
	0 - 65535	Minimum → Maximum Intensity	Fade	0
7-8		Blue		
	0 - 65535	Minimum → Maximum Intensity	Fade	0
9**		Extended Controls		
	0 - 255	See Control channel table for details	Snap	0

Note: The white point is set in RDM (set Fixed CCT 0-255 default 127 - 4440K) (set Fixed Tint 0-255 default 127)

** An additional control channel can be enabled and will always be positioned as the last channel and it is 8-bit even when 16-bit personality is set.

Chroma-Q® 2inspire™100/200/300 (IHS) – Intensity, Hue, Saturation Personality

IHS – Intensity, Hue(color) and Saturation (from white to color): This personality uses three DMX channels. You can regulate the light's intensity, its hue (the base color), and saturation (the richness or purity of the color). The white point is set in RDM.

8-bit

Channel	Value	Function	Fade Status	Default Value
1		Intensity		
	0 - 255	Minimum → Maximum Intensity	Fade	0
2		Hue		
	0 - 255	Red>Orange>Yellow>Green>Cyan>Blue>Magenta>Red	Fade	0
3		Saturation		
	0 - 255	White > Color	Fade	0
4**		Extended Controls		
	0 - 255	See Control channel table for details	Snap	0

16-bit

Channel	Value	Function	Fade Status	Default Value
1-2		Intensity		
	0 - 65535	Minimum → Maximum Intensity	Fade	0
3-4		Hue		
	0 - 65535	Red>Orange>Yellow>Green>Cyan>Blue>Magenta>Red	Fade	0
5-6		Saturation		
	0 - 65535	White > Color	Fade	0
7**		Extended Controls		
	0 - 255	See Control channel table for details	Snap	0

Note: The white point is set in RDM (set Fixed CCT 0-255 default 127 - 4440K) (set Fixed Tint 0-255 default 127)

An additional control channel can be enabled and will always be positioned as the last channel and it is 8-bit even when 16-bit personality is set.

**

Chroma-Q® 2inspire™100/200/300 (IKTRGB) Intensity, CCT, Tint, RGB Personality

IKTRGB - Intensity, CCT, Tint, RGB+magic white: This personality is a comprehensive combination of the previous ones. It gives control over intensity, color temperature (CCT), tint (green-magenta bias), and full RGB color control.

8-bit

Channel	Value	Function	Fade Status	Default Value
1		Intensity		
	0 - 255	Minimum → Maximum Intensity	Fade	0
2		Corelated Color Temperature (CCT in Kelvin)		
	0	2400K	Fade	127
	25	2800K		
	50	3200K		
	75	3600K		
	100	4000K		
	127	4440K (Neutral)		
	150	4800K		
	175	5200K		
	200	5600K		
	225	6000K		
255	6500K			
3		Tint (plus/minus green)		
	0	-2	Fade	127
	127	0 (Neutral)		
255	+2			
4		Red		
	0 - 255	Minimum → Maximum Intensity	Fade	0
5		Green		
	0 - 255	Minimum → Maximum Intensity	Fade	0
6		Blue		
	0 - 255	Minimum → Maximum Intensity	Fade	0
7**		Extended Controls		
	0 - 255	See Control channel table for details	Snap	0

Chroma-Q® 2inspire™100/200/300 (IKTRGB) Intensity, CCT, Tint, RGB Personality

16-bit

Channel	Value	Function	Fade Status	Default Value
1-2		Intensity		
	0 - 65535	Minimum → Maximum Intensity	Fade	0
3-4		Corelated Color Temperature (CCT in Kelvin)		
	0	2400K	Fade	32767
	6400	2800K		
	12800	3200K		
	19200	3600K		
	25600	4000K		
	32767	4440K (Neutral)		
	38400	4800K		
	44800	5200K		
	51200	5600K		
	57600	6000K		
65535	6500K			
5-6		Tint (plus/minus green)		
	0	-2	Fade	32767
	32767	0 (Neutral)		
65535	+2			
7-8		Red		
	0 - 65535	Minimum → Maximum Intensity	Fade	0
9-10		Green		
	0 - 65535	Minimum → Maximum Intensity	Fade	0
11-12		Blue		
	0 - 65535	Minimum → Maximum Intensity	Fade	0
13**		Extended Controls		
	0 - 255	See Control channel table for details	Snap	0

Note: Pure white is when Red, Green, Blue are at maximum, color temperature and tint of white is selected by the CCT and Tint channels

An additional control channel can be enabled and will always be positioned as the last channel and it is 8-bit even when 16-bit personality is set.

**

Chroma-Q® 2inspire™100/200/300 (IKTHS) Intensity, CCT, Saturation, Hue Personality

IKTHS - Intensity, CCT, Tint, Hue, Saturation+magic white: This Personality provides in-depth color control. You can adjust the fixture's intensity, color temperature (CCT), green-magenta tint, the base hue, and the saturation.

8-bit

Channel	Value	Function	Fade Status	Default Value
1		Intensity		
	0 - 255	Minimum → Maximum Intensity	Fade	0
2		Corelated Color Temperature (CCT in Kelvin)		
	0	2400K	Fade	127
	25	2800K		
	50	3200K		
	75	3600K		
	100	4000K		
	127	4440K(Neutral)		
	150	4800K		
	175	5200K		
	200	5600K		
	225	6000K		
	255	6500K		
3		Tint (plus/minus green)		
	0	-2	Fade	127
	127	0 (Neutral)		
255	+2			
4		Hue		
	0 - 255	Red>Orange>Yellow>Green>Cyan>Blue>Magenta>Red	Fade	0
5		Saturation		
	0 - 255	White > Color	Fade	0
6**		Extended Controls		
	0 - 255	See Control channel table for details	Snap	0

Chroma-Q® 2inspire™100/200/300 (IKTHS) Intensity, CCT, Saturation, Hue Personality

16-bit

Channel	Value	Function	Fade Status	Default Value
1-2		Intensity		
	0 - 65535	Minimum → Maximum Intensity	Fade	0
3-4		Corelated Color Temperature (CCT in Kelvin)		
	0	2400K	Fade	32767
	6400	2800K		
	12800	3200K		
	19200	3600K		
	25600	4000K		
	32767	4440K(Neutral)		
	38400	4800K		
	44800	5200K		
	51200	5600K		
	57600	6000K		
65535	6500K			
5-6		Tint (plus/minus green)		
	0	-2	Fade	32767
	32767	0 (Neutral)		
65535	+2			
7-8		Hue		
	0 - 255	Red>Orange>Yellow>Green>Cyan>Blue>Magenta>Red	Fade	0
9-10		Saturation		
	0 - 255	White > Color	Fade	0
11**		Extended Controls		
	0 - 255	See Control channel table for details	Snap	0

Note: Pure white is when Red, Green, Blue are at maximum, color temperature and tint of white is selected by the CCT and Tint channels

** An additional control channel can be enabled and will always be positioned as the last channel and it is 8-bit even when 16-bit personality is set.

Chroma-Q® 2inspire™100/200/300 **(CRTL) Control channel

Function name	Delay	Default	Start	End	Description
	Ms				Values must be held for 2 sec before its function is activated
Control channel					
No Function			0	2	
Dimmer Curve					
Dimmer curve Linear	2000		3	3	Linear
Dimmer curve Square Law	2000	X	4	4	This curve gives more resolution in the 0-20% and accelerate after
Dimmer curve Inv Square Law	2000		5	5	Faster ramp up
Dimmer curve S-curve	2000		6	6	This curve gives more resolution in the 0-20% and 80%-100%
No Function					
No Function			7	10	
DMX Smoothing					
DMX Smoothing Off	1000		11	12	No DMX interpolations perform, very dynamic reaction for pixel mapping
DMX Smoothing Normal	1000	X	13	14	Insures that intensity and color fades are nice and even
No Function					
No Function			15	716	
CCT and Tint control effect					
CCT, Tint on Saturated color - Disabled	1000		17	18	When Disabled, the CCT and Tint control channel or fix point will not influence on fully saturated color
CCT, Tint on Saturated color - Enabled	1000	X	19	20	When Enabled, the CCT and Tint control channel or fix point will influence fully saturated color
No Function					
No Function			21	70	
PWM Frequency					
PWM 1500	2000		71	72	Set PMW rate at 1500hz, internal dimming resolution is 16 bit
PWM 3000	2000		73	74	Set PMW rate at 3000hz, internal dimming resolution is 15 bit
PWM 6000	2000	X	75	76	Set PMW rate at 6000hz, internal dimming resolution is 14 bit
PWM 12000	2000		77	78	Set PMW rate at 12,000hz, internal dimming resolution is 13 bit
PWM 24000	2000		79	80	Set PMW rate at 24,000hz, internal dimming resolution is 12 bit

PWM 48000	2000		81	82	Set PMW rate at 48,000hz, internal dimming resolution is 11 bit
PWM 96000	2000		83	84	Set PMW rate at 96,000hz, internal dimming resolution is 10 bit
PWM 192000	2000		85	86	Set PMW rate at 192,000hz, internal dimming resolution is 9 bit
					Lower frequency = smoother dimming, Higher frequency = less flicker on camera, 3000 or 6000hz works in 99% of the situations.
No Function			87	150	
DMX Lost					
DMX Lost default Fixture stay to the last state	2000	X	151	152	
DMX Lost default Fixture goes black (after delay)	2000		153	154	Default delay is 5 minutes, can be changed in menu
DMX Lost default Fixture goes to full (after delay)	2000		155	156	Default delay is 5 minutes, can be changed in menu, full means a white output according to the DMX Personality
DMX Lost default fixture to save look (after delay)	2000		157	158	Default delay is 5 minutes, can be changed in menu
No Function			159	235	
Store Failsafe scene	2000		236	237	Set the desired look using the parameters, Then on CTRL channel, Select this option, then leave on this value for 3 seconds
No Function			238	239	
Reset	5000		240	242	Force a fixture reboot
No Function			243	243	
Default					
Save as User Defaults	5000		244	245	Take the current settings and make it the new default (except DMX address and DMX Personality)
Restore User Defaults(1)	5000		246	247	Restore setting to user default (except DMX address and DMX Personality)
Restore Factory Defaults	5000		248	249	Restore setting to factory default (except DMX address and DMX Personality)
No Function			250	255	No Function

Chroma-Q® 2inspire™100/200/300 CCT control

For IK, IKT, IKTRGB, IKTHS Personalities

DMX 8bit	16 bit	Kelvin	DMX 8bit	16 bit	Kelvin	DMX 8bit	16 bit	Kelvin	DMX 8bit	16 bit	Kelvin
0	0	2400	64	16384	3429	128	32768	4458	192	49152	5487
1	256	2416	65	16640	3445	129	33024	4474	193	49408	5503
2	512	2432	66	16896	3461	130	33280	4490	194	49664	5519
3	768	2448	67	17152	3477	131	33536	4506	195	49920	5535
4	1024	2464	68	17408	3493	132	33792	4522	196	50176	5551
5	1280	2480	69	17664	3509	133	34048	4538	197	50432	5567
6	1536	2496	70	17920	3525	134	34304	4555	198	50688	5584
7	1792	2513	71	18176	3542	135	34560	4571	199	50944	5600
8	2048	2529	72	18432	3558	136	34816	4587	200	51200	5616
9	2304	2545	73	18688	3574	137	35072	4603	201	51456	5632
10	2560	2561	74	18944	3590	138	35328	4619	202	51712	5648
11	2816	2577	75	19200	3606	139	35584	4635	203	51968	5664
12	3072	2593	76	19456	3622	140	35840	4651	204	52224	5680
13	3328	2609	77	19712	3638	141	36096	4667	205	52480	5696
14	3584	2625	78	19968	3654	142	36352	4683	206	52736	5712
15	3840	2641	79	20224	3670	143	36608	4699	207	52992	5728
16	4096	2657	80	20480	3686	144	36864	4715	208	53248	5744
17	4352	2673	81	20736	3702	145	37120	4731	209	53504	5760
18	4608	2689	82	20992	3718	146	37376	4747	210	53760	5776
19	4864	2705	83	21248	3735	147	37632	4764	211	54016	5793
20	5120	2722	84	21504	3751	148	37888	4780	212	54272	5809
21	5376	2738	85	21760	3767	149	38144	4796	213	54528	5825
22	5632	2754	86	22016	3783	150	38400	4812	214	54784	5841
23	5888	2770	87	22272	3799	151	38656	4828	215	55040	5857
24	6144	2786	88	22528	3815	152	38912	4844	216	55296	5873
25	6400	2802	89	22784	3831	153	39168	4860	217	55552	5889
26	6656	2818	90	23040	3847	154	39424	4876	218	55808	5905
27	6912	2834	91	23296	3863	155	39680	4892	219	56064	5921
28	7168	2850	92	23552	3879	156	39936	4908	220	56320	5937
29	7424	2866	93	23808	3895	157	40192	4924	221	56576	5953
30	7680	2882	94	24064	3911	158	40448	4940	222	56832	5969
31	7936	2898	95	24320	3927	159	40704	4956	223	57088	5985
32	8192	2915	96	24576	3944	160	40960	4973	224	57344	6002
33	8448	2931	97	24832	3960	161	41216	4989	225	57600	6018
34	8704	2947	98	25088	3976	162	41472	5005	226	57856	6034
35	8960	2963	99	25344	3992	163	41728	5021	227	58112	6050
36	9216	2979	100	25600	4008	164	41984	5037	228	58368	6066
37	9472	2995	101	25856	4024	165	42240	5053	229	58624	6082
38	9728	3011	102	26112	4040	166	42496	5069	230	58880	6098
39	9984	3027	103	26368	4056	167	42752	5085	231	59136	6114
40	10240	3043	104	26624	4072	168	43008	5101	232	59392	6130
41	10496	3059	105	26880	4088	169	43264	5117	233	59648	6146
42	10752	3075	106	27136	4104	170	43520	5133	234	59904	6162
43	11008	3091	107	27392	4120	171	43776	5149	235	60160	6178
44	11264	3107	108	27648	4136	172	44032	5165	236	60416	6195
45	11520	3124	109	27904	4153	173	44288	5182	237	60672	6211
46	11776	3140	110	28160	4169	174	44544	5198	238	60928	6227
47	12032	3156	111	28416	4185	175	44800	5214	239	61184	6243
48	12288	3172	112	28672	4201	176	45056	5230	240	61440	6259
49	12544	3188	113	28928	4217	177	45312	5246	241	61696	6275
50	12800	3204	114	29184	4233	178	45568	5262	242	61952	6291
51	13056	3220	115	29440	4249	179	45824	5278	243	62208	6307
52	13312	3236	116	29696	4265	180	46080	5294	244	62464	6323
53	13568	3252	117	29952	4281	181	46336	5310	245	62720	6339
54	13824	3268	118	30208	4297	182	46592	5326	246	62976	6355
55	14080	3284	119	30464	4313	183	46848	5342	247	63232	6371
56	14336	3300	120	30720	4329	184	47104	5358	248	63488	6387
57	14592	3316	121	30976	4345	185	47360	5375	249	63744	6404
58	14848	3333	122	31232	4362	186	47616	5391	250	64000	6420
59	15104	3349	123	31488	4378	187	47872	5407	251	64256	6436
60	15360	3365	124	31744	4394	188	48128	5423	252	64512	6452
61	15616	3381	125	32000	4410	189	48384	5439	253	64768	6468
62	15872	3397	126	32256	4426	190	48640	5455	254	65024	6484
63	16128	3413	127	32512	4442	191	48896	5471	255	65280	6500

RDM Commands

RDM Standard commands

Supported RDM parameters:	Definitions
DEVICE_INFO	
IDENTIFY_DEVICE	When enabled the fixture will blink
DMX_START_ADDRESS	Display the current DMX address
SOFTWARE_VERSION_LABEL	Display the current firmware version
DEVICE_LABEL	User definable label
SENSOR_DEFINITION	
PARAMETER_DESCRIPTION	
DMX_PERSONALITY	
DMX_PERSONALITY_DESCRIPTION	
DEVICE_MODEL_DESCRIPTION	2Inspire 100 or 200 or 300
Failsafe	Use RDM Command instead
MANUFACTURER_LABEL	Chroma-Q
DEVICE_LABEL	
SENSOR_DEFINITION	
SENSOR_VALUE	
RESET_DEVICE	
IP Address	Display current fixture IP address

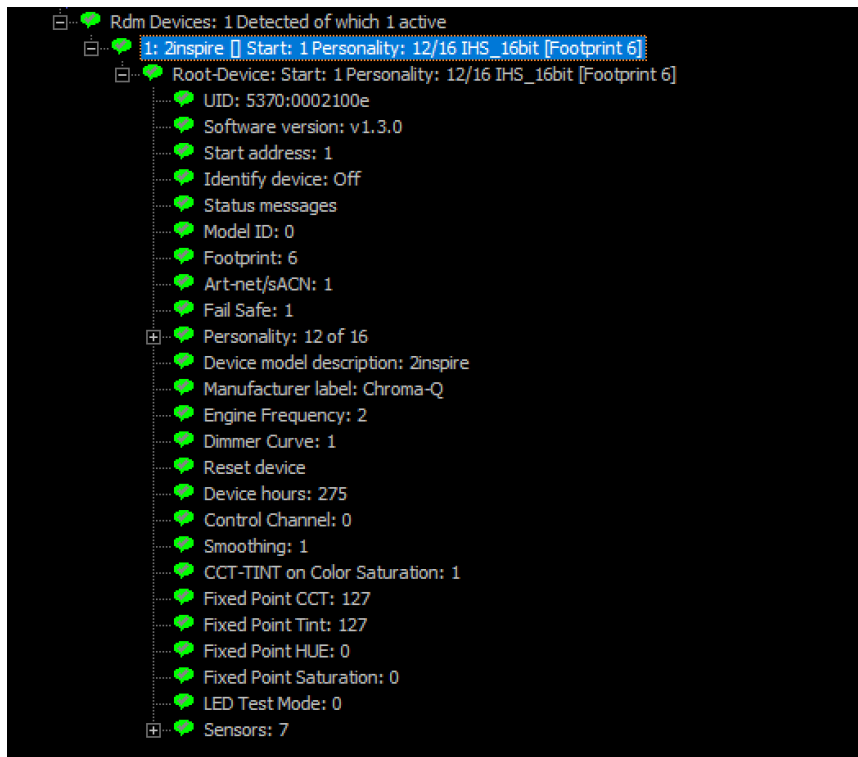

RDM Custom commands

Art-Net /sACN [0xFFE3]	0=Art-Net, 1=sACN Select the communication protocol for DMX
Failsafe [0xFFE2]	0=Blackout, 1=Hold Last State, 2=Go to full white, 3= Go to store scene 4=Store current values Set the behavior when the fixture does not receive any valid DMX signal
Personality: X of 16	
	1: i [Footprint 1]
	2: I_16bit [Footprint 2]
	3: ik [Footprint 2]
	4: IK_16bit [Footprint 4]
	5: ikt[Footprint 3]
	6: IKT_16bit [Footprint 6]
	7: RGB [Footprint 3]
	8: RGB_16bit [Footprint 6]
	9: IRGB [Footprint 4]
	10: IRGB_16bit [Footprint 8]
	11: IHS [Footprint 3]
	12: IHS_16bit [Footprint 6]
Default	13: IKT-RGB [Footprint 6]
	14: IKT-RGB_16bit [Footprint 12]
	15: IKT-HS [Footprint 5]
	16: IKT-HS_16bit [Footprint 10]
Device model description: 2inspire XXX	
Manufacturer label: Chroma-Q	
Engine Frequency [0xFFD3]	0 to 7 (0=1500, 1=3000, 2=6000 , 3=12000, 4=24000, 5=48000, 6=96000, 7=192000 hz) Lower frequency = smoother dimming, Higher frequency = less flicker on camera, 3000 or 6000hz works in 99% of the situations.
Dimmer Curve [0xFFDD]	0=Linear, 1=Sqr Law ,2=Inv Sqr Law, 3=S Curve (default=1) Select the desired dimmer curve
Reset device	
Device hours [0x0400]	
Control Channel [0xFFD5]	0=Off, 1=Enabled When enabled, an extra DMX channel is added at the end. See DMX Extended Control
Smoothing [0xFFD7]	0=Off, 1=Normal When off, the fixture is quicker to react to DMX changes, but not as smooth in slow transition Quicker reaction time can be useful for certain dynamic effects such as a pixel-mapping
CCT-Tint on Color Saturation [0xFFE0]	0:Off, 1:On . When on, in personalities using CCT and Tint control, these latter will affect the saturated color as well. See Color Control explanation
Fixed Point CCT [0xFFDB]	0-255 (default 127) Set the color temperature value for personalities that don't have a CCT control
Fixed Point Tint [0xFFDC]	0-255 (default 127) Set the tint value for personalities that don't have a Tint control
Fixed Point HUE [0xFFDE]	0-255 (default 0) Set the color value for personalities that don't have a HUE or RGB control 0=Red, 42= Yellow, 85= Green, 127=Cyan, 169=Blue, 212=Magenta, 255= Red
Fixed Point Saturation [0xFFDF]	0-255 (default 0) Set the color saturation value for personalities that don't have a Saturation control
LED Test Mode [0xFFE1]	0 = Off, 1= On. When enabled, then fixture will turn each color channels on in a sequence.

Dimmer curves

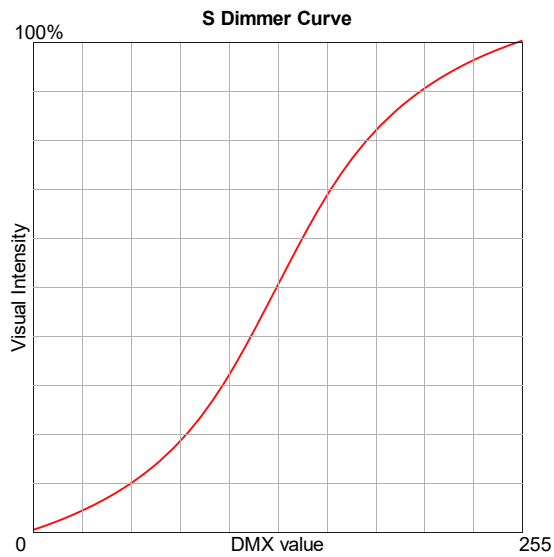
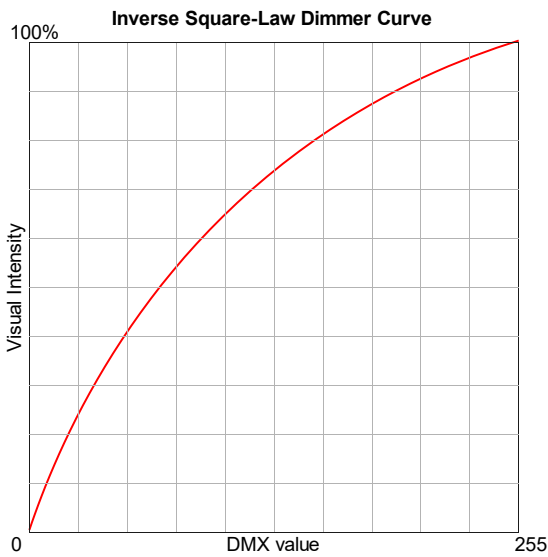
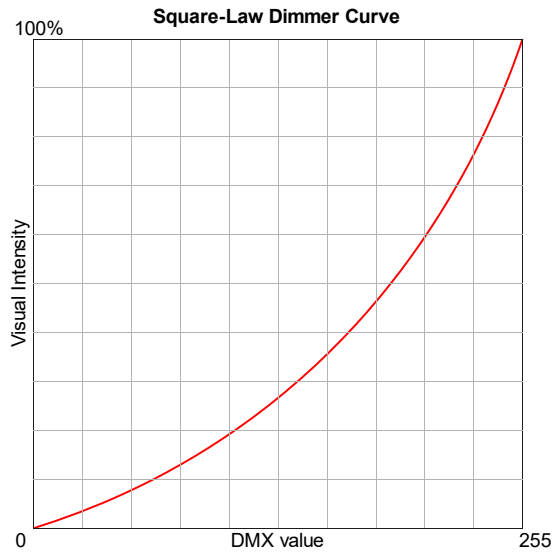
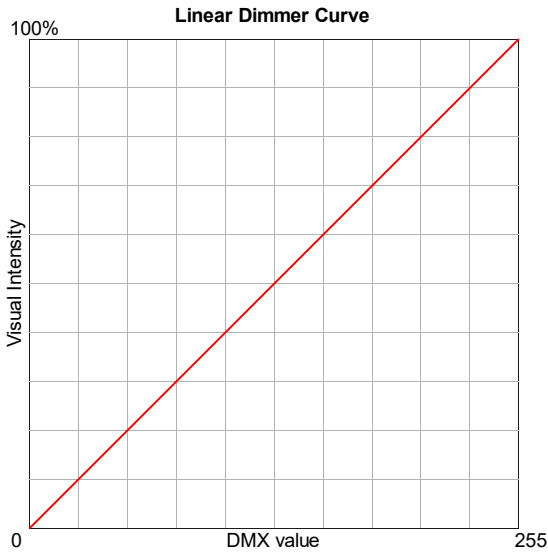

Hue and Saturation control

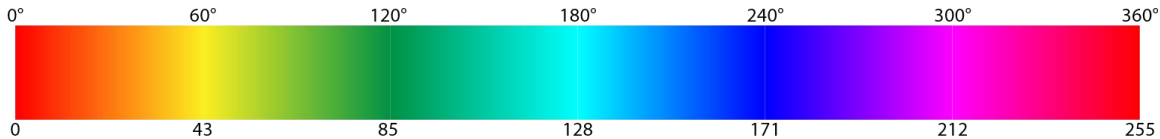

The Hue (H) control, combined with the Saturation (S) control, allows for the selection of any possible color within the color space of the fixture. Imagine Hue as choosing a color along the edge of the color space triangle, and Saturation as the boldness or lightness control of this selected color. With a Saturation of 0, the result will always be white, and that white point is set by the CCT (K) and Tint (T) controls.

Thermal Performance

The fixture utilizes a convection-based internal cooling system. In addition, it is equipped with an automatic protection feature that reduces the output when the internal temperature reaches the maximum limit, especially in extreme ambient conditions. Please refer to the [specifications](#) section for the operating temperature range.

Troubleshooting

Troubleshooting is a process of elimination. First, rule out the other field factors (i.e. Bad connections, faulty cables and power supplies). For technical support and/or parts, please contact your selling dealer or the offices listed in this manual.

Symptom	Possible Cause	Solution
Fixture does not respond to DMX control.	Set to wrong or different DMX address. Bad ethernet cable connecting Ethernet POE switch/ or PoE Injector or Chroma-Q 2inspire PSE. And fixture. Bad POE Switch or PoE Injector or Chroma-Q 2inspire PSE. DMX Personality set incorrectly.	Check DMX address and Personality settings. Check/replace cable Check/replace POE Switch/injector
Low LED output.	Internal temperature is over the limit.	Check unit temperature via RDM. Check area ventilation.
Flickering on camera.	Frequency set incorrectly.	Change PWM frequency in RDM commands.
Fixture not responding after powered up	Bad firmware	Reset the internal firmware using the reset switch
Single color like, Red, Green, Blue appears to be washed out	CCT and/or Tint control are not set at 50% (DMX 127)	When deep saturated color are needed, ensure to have CCT and Tint in neutral position 50% (DMX 127)
In I, IK, IKT, RGB, HSI, White are not the same color temperature on all fixtures	RDM settings for <u>Fixed Point CCT</u> and <u>Fixed Point Tint</u> are different	Change the RDM settings so all fixtures are the same.
The fixture is powered and receiving data (blinking LED near RJ45) but it is not being discovered by any RDM software or RDM controllers.	The IP address and/or Subnet might be different than the current IP on the RDM controller.	Set the controller IP range /Subnet to the same as the fixture. If the IP range /Subnet is unknown, See Reset Fixture

Reset / Test Switch

The 2inspire™ fixtures have a hidden switch to test and reset the fixture settings. To access the switch, a small pin is needed. A paper clip or a round toothpick can be used.

Note: The switch is a simple metallic dome; it can be difficult to find the first time it's being done.

- Holding the switch for 100 milliseconds will turn on the fixture in white at 100% output, CCT 127, Tint 127
- Holding the switch for 3 second will reset all settings to factory default (excluding address and personality)
- Holding the switch for 10 second will reset all settings to factory default (including address and personality)
- Holding the switch for 15 second will rollback the firmware to factory default**
- Holding the switch while powering up will rollback the firmware to factory default**

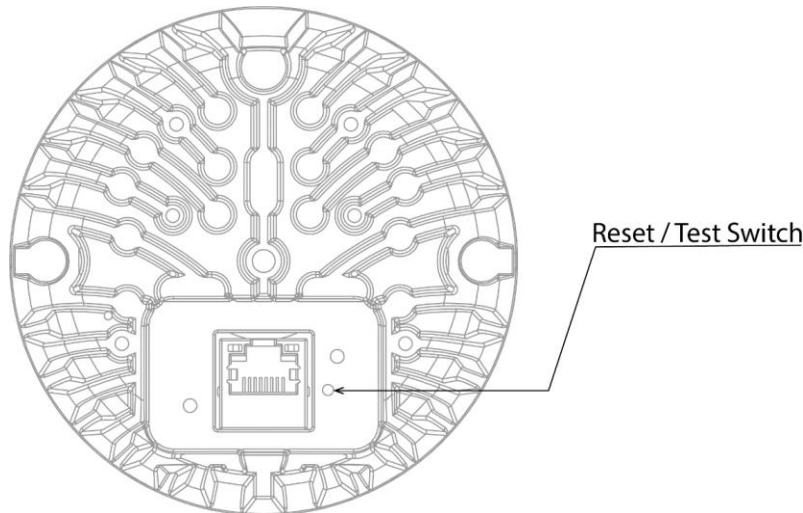

Updating the fixture firmware

Throughout the life of the fixture, new functionalities may be added or certain bugs fixed. The fixture firmware can be updated using Chroma-Q The Force or the [Chroma-Q Ethernet Updater software](#). Instructions and uploader software are included with the firmware file available on the [2inspire webpage](#). It is crucial to disconnect or turn off any DMX/RDM transmitter when updating the firmware

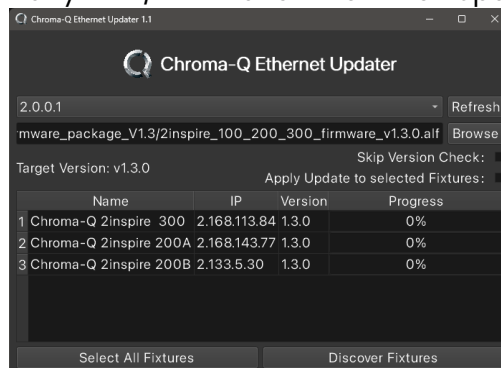

Maintenance

- Please be informed that the lighting fixtures in use are sealed units and do not require regular maintenance. The sealed design ensures optimal performance and eliminates the need for any internal servicing or component replacements. However, it is still essential to adhere to the following guidelines to maximize the lifespan and efficiency of the fixtures.
- **Cleaning:** Periodically clean the external surface of the fixtures using a soft, lint-free cloth. Ensure that the fixtures are switched off and disconnected from the power source before cleaning.
- **Visual Inspection:** Routinely inspect the fixtures for any signs of physical damage, such as cracks, dents, or loose parts. If any issues are detected, please contact the maintenance team immediately.
- **Environmental Considerations:** Keep the fixtures away from extreme temperatures, excessive humidity, corrosive substances, and direct exposure to sunlight or water. Such conditions may affect the performance and longevity of the fixtures.
- **Power Supply:** Verify that the fixtures are receiving a stable power supply within the specified voltage range. Any fluctuations or irregularities in the power source should be addressed promptly to prevent any potential damage.
- **Professional Assistance:** If you encounter any technical issues or concerns with the sealed lighting fixtures, please consult a qualified technician or reach out to the manufacturer's customer support for assistance. Do not attempt to disassemble or repair the fixtures yourself.
- By adhering to these maintenance guidelines, you can ensure optimal performance and prolong the lifespan of the sealed lighting fixtures. If you have any further questions or require support, please do not hesitate to contact us.

Tips and tricks

- Update fixture firmware, test and set RDM settings before installing
- Have a PC with latest version of DMX-Workshop
- Network adapter on 2.0.0.1 / Subnet 255.0.0.0
- Ensure enough power on PoE switch
- If available, "power reserve" on PoE switch should be disabled.
- Use CAT6e cable. There is no need for shielded cable.
- Have the fixtures on an isolated network, or its own VLAN
- Maximum 12 DMX universe in Art-Net Broadcast
- Art-Net Unicast has no real limit
- Use sACN when possible, it is more efficient and less restrictive than Art-Net Broadcast
- sACN makes use of IGMP
- Try limiting DMX refresh to 30hz
- Only one RDM transmitter
- IP fixtures must have diffusion install first.
- The default DMX mode is IKTRGB. It is the most flexible mode to use on this fixture.
- The K (CCT) and T (Tint) should default to 50% (127) to achieve neutral white and colors.

Specifications

Technical Specifications

	2inspire™100	2inspire™200	2inspire™300
Product Code	CQ1501-1000 Chroma-Q 2inspire 100 Black IP20 CQ1501-1005 Chroma-Q 2inspire 100 White IP20 CQ1501-1010 Chroma-Q 2inspire 100 Black IP65 CQ1501-1015 Chroma-Q 2inspire 100 White IP65	CQ1502-1000 Chroma-Q 2inspire 200 Black IP20 CQ1502-1005 Chroma-Q 2inspire 200 White IP20 CQ1502-1010 Chroma-Q 2inspire 200 Black IP65 CQ1502-1015 Chroma-Q 2inspire 200 White IP65	CQ1503-1000 Chroma-Q 2inspire 300 Black IP20 CQ1503-1005 Chroma-Q 2inspire 300 White IP20 CQ1503-1010 Chroma-Q 2inspire 300 Black IP65 CQ1503-1015 Chroma-Q 2inspire 300 White IP65
Net Dimensions (Without Fixings – Diameter x Length)	ø 93 mm x 109 mm lg ø 3.6" x 4.25" lg	ø 118 mm x 147 mm lg ø 4.65" x 5.79" lg	ø 146 mm x 196 mm lg ø 5.75" x 7.72" lg
Net Weight	0.81 kg / 1.79 lb (Without Yoke)	1.36 kg / 2.99 lb (Without Yoke)	2.5 kg / 5.51 lb (Without Yoke)
Shipping Dimensions - Length x Width x Depth	127 mm x 127 mm x 152 mm 5" x 5" x 6"	179 mm x 179 mm x 203 mm 7" x 7" x 8"	203 mm x 203 mm x 254 mm 8" x 8" x 10"
Shipping Weight	0.97 kg / 2.14 lb	1.65 kg / 3.64 lb	2.91 kg / 6.42 lb
Power & Connections	DC PoE, RJ45	DC PoE, RJ45	DC PoE, RJ45
Power Supply (Not Supplied with Fixture)	PoE+, (Up to 30W)	PoE++, (Up to 60W)	UPoE+, (Up to 90W)
Power Input Rating	48-56 VDC, PoE+	48-56 VDC, PoE++	48-56 VDC, UPOE+
Power Consumption	25W	35W	65W
Rated input current	0.4A	0.7A	1.2A
Idle Power Consumption	3W	3W	3W
Typical Power & Current	Measurements done with all leds at max. Intensity. Measurements made at nominal voltage. Allow for deviation of +/- 10%.	Measurements done with all leds at max. Intensity. Measurements made at nominal voltage. Allow for deviation of +/- 10%.	Measurements done with all leds at max. Intensity. Measurements made at nominal voltage. Allow for deviation of +/- 10%.
Control Protocol	Art-Net™, sACN	Art-Net™, sACN	Art-Net™, sACN
Cooling System	Convection	Convection	Convection
Operating Temperature	0°C to 40°C	0°C to 40°C	0°C to 40°C
Construction	Powder-coated aluminum	Powder-coated aluminum	Powder-coated aluminum
Color	Black / White	Black / White	Black / White
IP Rating	IP20 / IP65	IP20 / IP65	IP20 / IP65
Approvals	This device complies with Part 15 of the FCC Rules. Operation is subject to the following two conditions: (1) this device may not cause harmful interference, and (2) this device must accept any interference received, including interference that may cause undesired operation	This device complies with Part 15 of the FCC Rules. Operation is subject to the following two conditions: (1) this device may not cause harmful interference, and (2) this device must accept any interference received, including interference that may cause undesired operation	This device complies with Part 15 of the FCC Rules. Operation is subject to the following two conditions: (1) this device may not cause harmful interference, and (2) this device must accept any interference received, including interference that may cause undesired operation
Lumen Output in Lumens (combined)	840 lm to 940 lm	1100 lm to 1400 lm	2100 lm to 3100 lm
Optics	Fully Homogenized	Fully Homogenized	Fully Homogenized
Beam Angle	≈ 20°	≈ 19°	≈ 26°
Beam Distribution	Symmetrical Direct Illumination	Symmetrical Direct Illumination	Symmetrical Direct Illumination
CCT	2400K to 6500K	2400K to 6500K	2400K to 6500K
CRI	>90	>90	>90
Sound Level	Idle Sound Level 30.72 db Maximum Sound Level 31.44 db	Idle Sound Level 29.03 db Maximum Sound Level 29.45 db	Idle Sound Level 28.46 db Maximum Sound Level 29.58 db
Lamp Life	L70 at 50,000 hours*		

*Measured under manufacturer's test conditions

** For exact measurements please refer to the line drawings below

www.chroma-q.com



Drawings – Measurements in Metric and Imperial

2inspire™100 line drawing

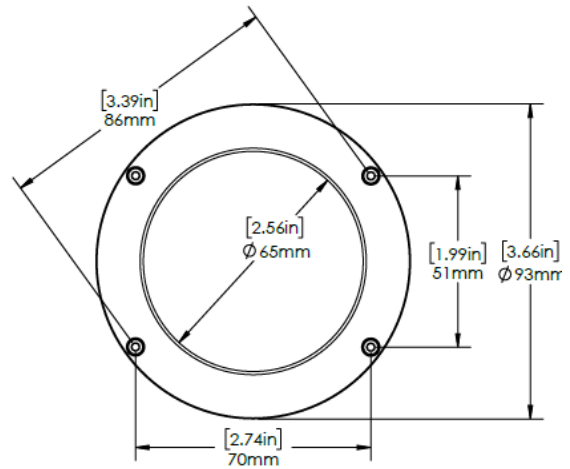
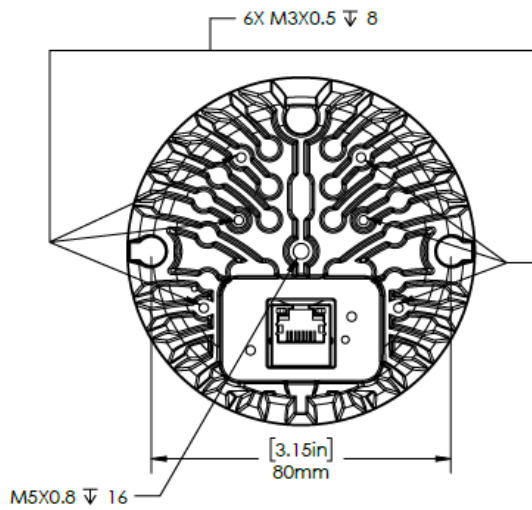
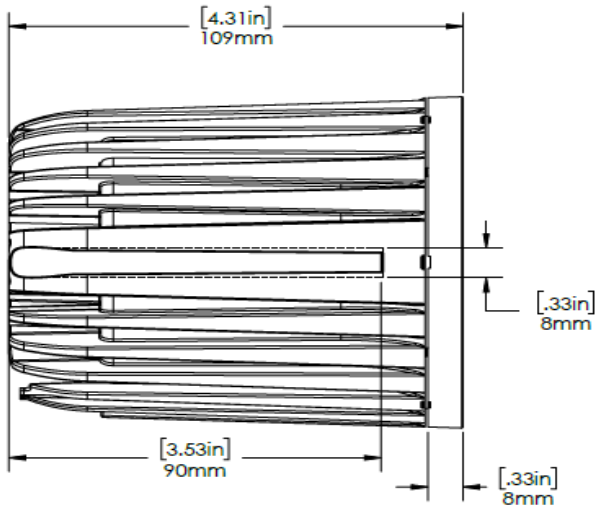

2inspire™ 200 line drawing

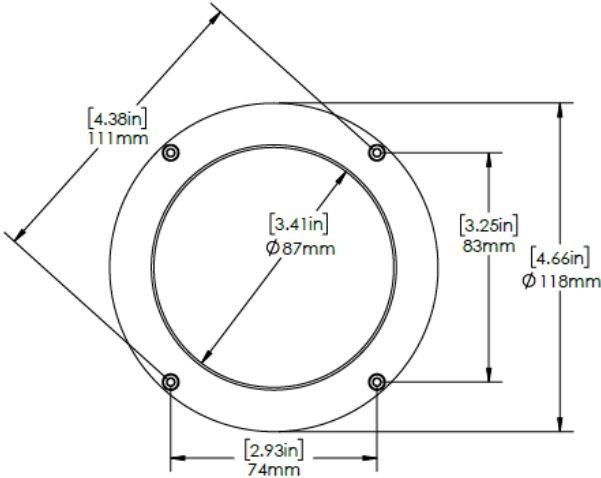
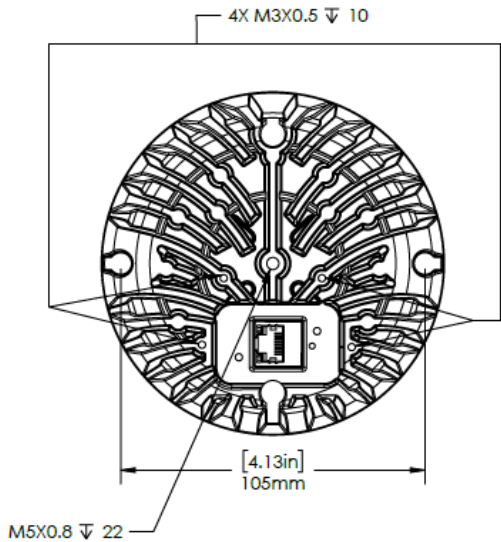
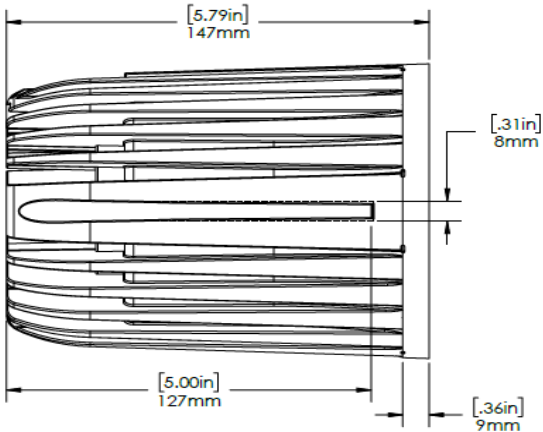

2inspire™ 300 line drawing

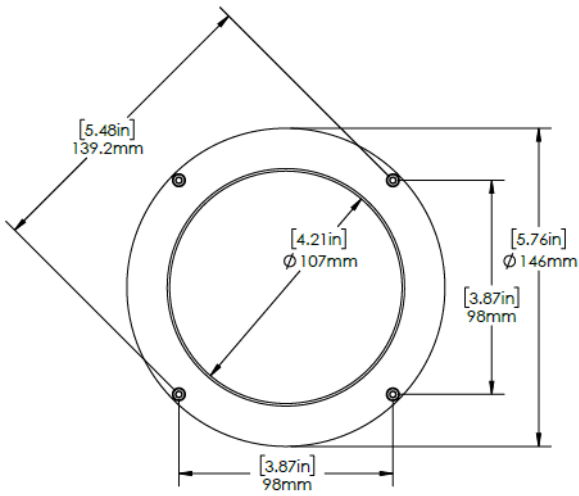
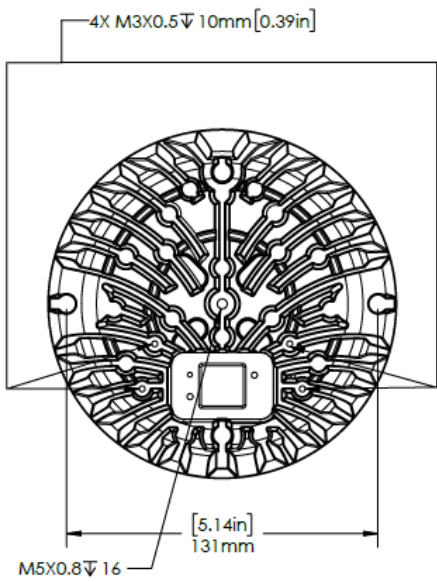
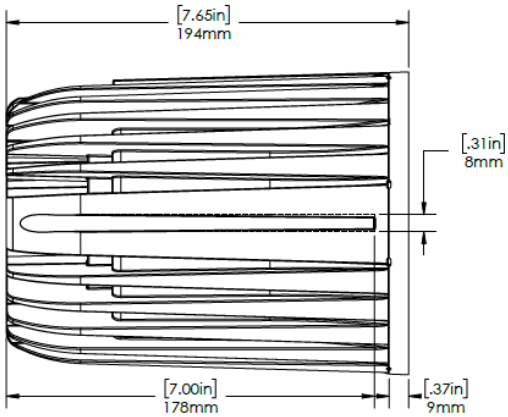

Accessories

Common to all three models

CQ1509-9001	2inspire Wall Mount Short Black
CQ1509-9002	2inspire Wall Mount Short White
CQ1509-9011	2inspire Pendant Mount Kit (W/O Stem, W/O Yoke) Black
CQ1509-9012	2inspire Pendant Mount Kit (W/O Stem, W/O Yoke) White
CQ1509-9016	2inspire Pendant Stem 1ft, 300mm Black
CQ1509-9017	2inspire Pendant Stem 1ft, 300mm White
CQ1509-9021	2inspire Pendant Stem 2ft, 600mm Black
CQ1509-9022	2inspire Pendant Stem 2ft, 600mm White
CQ1509-9026	2inspire Pendant Stem 3ft, 900mm Black
CQ1509-9027	2inspire Pendant Stem 3ft, 900mm White

2inspire 100 Accessories

CQ1509-9106	2inspire 100 Yoke Black*
CQ1509-9107	2inspire 100 Yoke White*
CQ1509-9111	2inspire 100 Shroud for Pendant Mount Kit Black**
CQ1509-9112	2inspire 100 Shroud for Pendant Mount Kit White**
CQ1509-9116	2inspire 100 Blind Ceiling Mount Flush 0o Black
CQ1509-9117	2inspire 100 Blind Ceiling Mount Flush 0o White
CQ1509-9118	2inspire 100 Blind Ceiling Mount Recessed 0o Black
CQ1509-9119	2inspire 100 Blind Ceiling Mount Recessed 0o White
CQ1509-9121	2inspire 100 Blind Slant Ceiling Mount 0o Black
CQ1509-9122	2inspire 100 Blind Slant Ceiling Mount 0o White
CQ1509-9126	2inspire 100 Blind Slant Ceiling Mount 0o - 25o Black
CQ1509-9127	2inspire 100 Blind Slant Ceiling Mount 0o - 25o White
CQ1509-9131	2inspire 100 Blind Slant Ceiling Mount 25o - 45o Black
CQ1509-9132	2inspire 100 Blind Slant Ceiling Mount 25o - 45o White
CQ1509-9136	2inspire 100 Honeycomb Louver Black
CQ1509-9137	2inspire 100 Honeycomb Louver White
CQ1509-9141	2inspire 100 Barndoor Black
CQ1509-9142	2inspire 100 Barndoor White
CQ1509-9146	2inspire 100 Snoot Black
CQ1509-9147	2inspire 100 Snoot White
CQ1509-9151	2inspire 100 Medium diffusion (pack of 10)
CQ1509-9156	2inspire 100 Wide diffusion (pack of 10)
CQ1509-9161	2inspire 100 Extra wide diffusion (pack of 10)
CQ1509-9166	2inspire 100 asymmetrical diffusion (pack of 10)
CQ1509-9171	2inspire 100 Gel Holder C Ring 10 packs Black
CQ1509-9172	2inspire 100 Gel Holder C Ring 10 packs White

2inspire 200 Accessories

CQ1509-9206	2inspire 200 Yoke Black*
CQ1509-9207	2inspire 200 Yoke White*
CQ1509-9211	2inspire 200 Shroud for Pendant Mount Kit Black**
CQ1509-9212	2inspire 200 Shroud for Pendant Mount Kit White**
CQ1509-9216	2inspire 200 Blind Ceiling Mount Flush 0o Black
CQ1509-9217	2inspire 200 Blind Ceiling Mount Flush 0o White
CQ1509-9218	2inspire 200 Blind Ceiling Mount Recessed 0o Black
CQ1509-9219	2inspire 200 Blind Ceiling Mount Recessed 0o White
CQ1509-9221	2inspire 200 Blind Slant Ceiling Mount 0o Black
CQ1509-9222	2inspire 200 Blind Slant Ceiling Mount 0o White
CQ1509-9226	2inspire 200 Blind Slant Ceiling Mount 0o - 25o Black
CQ1509-9227	2inspire 200 Blind Slant Ceiling Mount 0o - 25o White
CQ1509-9231	2inspire 200 Blind Slant Ceiling Mount 25o - 45o Black
CQ1509-9232	2inspire 200 Blind Slant Ceiling Mount 25o - 45o White
CQ1509-9236	2inspire 200 Honeycomb Louver Black
CQ1509-9237	2inspire 200 Honeycomb Louver White
CQ1509-9241	2inspire 200 Barndoor Black
CQ1509-9242	2inspire 200 Barndoor White
CQ1509-9246	2inspire 200 Snoot Black
CQ1509-9247	2inspire 200 Snoot White
CQ1509-9251	2inspire 200 Medium diffusion (pack of 10)
CQ1509-9256	2inspire 200 Wide diffusion (pack of 10)
CQ1509-9261	2inspire 200 Extra wide diffusion (pack of 10)
CQ1509-9266	2inspire 200 asymmetrical diffusion (pack of 10)
CQ1509-9271	2inspire 200 Gel Holder C Ring 10 packs Black
CQ1509-9272	2inspire 200 Gel Holder C Ring 10 packs White

2inspire 300 Accessories

CQ1509-9306	2inspire 300 Yoke Black*
CQ1509-9307	2inspire 300 Yoke White*
CQ1509-9311	2inspire 300 Shroud for Pendant Mount Kit Black**
CQ1509-9312	2inspire 300 Shroud for Pendant Mount Kit White**
CQ1509-9316	2inspire 300 Blind Ceiling Mount Flush 0o Black
CQ1509-9317	2inspire 300 Blind Ceiling Mount Flush 0o White
CQ1509-9318	2inspire 300 Blind Ceiling Mount Recessed 0o Black
CQ1509-9319	2inspire 300 Blind Ceiling Mount Recessed 0o White
CQ1509-9321	2inspire 300 Blind Slant Ceiling Mount 0o Black
CQ1509-9322	2inspire 300 Blind Slant Ceiling Mount 0o White
CQ1509-9326	2inspire 300 Blind Slant Ceiling Mount 0o - 25o Black
CQ1509-9327	2inspire 300 Blind Slant Ceiling Mount 0o - 25o White
CQ1509-9331	2inspire 300 Blind Slant Ceiling Mount 25o - 45o Black
CQ1509-9332	2inspire 300 Blind Slant Ceiling Mount 25o - 45o White
CQ1509-9336	2inspire 300 Honeycomb Louver Black
CQ1509-9337	2inspire 300 Honeycomb Louver White
CQ1509-9341	2inspire 300 Barndoor Black
CQ1509-9342	2inspire 300 Barndoor White
CQ1509-9346	2inspire 300 Snoot Black
CQ1509-9347	2inspire 300 Snoot White
CQ1509-9351	2inspire 300 Medium diffusion (pack of 10)
CQ1509-9356	2inspire 300 Wide diffusion (pack of 10)
CQ1509-9361	2inspire 300 Extra wide diffusion (pack of 10)
CQ1509-9366	2inspire 300 asymmetrical diffusion (pack of 10)
CQ1509-9371	2inspire 300 Gel Holder C Ring 10 packs Black
CQ1509-9372	2inspire 300 Gel Holder C Ring 10 packs White